



Distribution Code

Approved by CER

Version: V2.0
Date: October 2007

Issued by: Distribution System Operator
ESB Networks

CONTENTS

| | Page |
|--|-------------|
| PREFACE | (ii) |
| DISTRIBUTION GENERAL CONDITIONS | 2 |
| DISTRIBUTION PLANNING CODE | 6 |
| DISTRIBUTION CONNECTION CONDITIONS | 13 |
| GENERATOR REQUIREMENTS | 25 |
| DISTRIBUTION OPERATING CODE | 50 |
| DOC1 Demand Forecasting | 51 |
| DOC2 Operational Planning | 53 |
| DOC5 Demand Control | 55 |
| DOC7 Operational Communications and Liaison | 57 |
| DOC8 Event Reporting | 59 |
| DOC9 System Tests | 61 |
| DOC10 Monitoring, Testing and Investigation | 63 |
| DOC11 Safety Co-ordination | 64 |
| DISTRIBUTION DATA REGISTRATION CODE | 66 |
| Introduction | 67 |
| Schedule 1 Generating Unit Data | 69 |
| Schedule 2 Demand Forecasts | 74 |
| Schedule 3 Operational Planning | 75 |
| Schedule 4 System Design Information | 77 |
| Schedule 5 Load Characteristics | 79 |
| GLOSSARY AND DEFINITIONS | 80 |
| ANNEX 1 – Supplementary Publications | 88 |
| ANNEX 2 – Distribution Code Derogation Application form | 90 |

Preface

1. Industry Structure

The Electricity Supply Industry comprises the following principal bodies:-

- (a) The Transmission System Operator (TSO) operates the Transmission System. The Transmission System transports the electricity, generated by Generating Units, to the Distribution System, through which most customers will be supplied. Some Generating Plant is connected directly to the Distribution System and is referred to as Generation.
- (b) The Transmission System Asset Owner (TAO) owns the Transmission System. ESB holds the TAO licence.
- (c) The Distribution System Operator (DSO) is responsible for operating and maintaining a secure, reliable and efficient electricity Distribution System. The Distribution System transports electricity from the Transmission System or from Generation Units to the final customer. ESB holds the DSO licence.
- (d) Suppliers supply electricity to Customers. For this purpose, Suppliers will be entitled to use both the Transmission System and the Distribution System for the transport of electricity from Generating Units to Customers.
- (e) Generators generate electricity which is fed onto the Transmission or Distribution Systems. Generating Units are classified according to their voltage, output power and whether or not they are subject to Central Dispatch by the TSO.
- (f) Customers purchase electricity from Suppliers. Some Customers have their own generating plant for supplying all or part of their own needs. These are referred to as Customers with CHP or Customers with Auto-production.
- (g) Dispatchable Demand Customers are customers who are subject to Central Dispatch and have a Demand Reduction Capability of 4MW or more
- (h) The Commission was established by the Electricity Regulation Act 1999 to regulate the new Electricity Industry.
- (i) The Single Energy Market (SEM) is the wholesale all-island electricity market.

2. Use of the Distribution System

Use of the Distribution System may involve any of the following transactions:

- (a) A connection at entry to or exit from the Distribution System. An entry point is the connection between the Distribution System and the Transmission System or an Generating Plant. An exit point is the connection between the Distribution System and the Customer's premises.
- (b) Use of the Distribution System to transport electricity between entry and exit points
- (c) Construction of a Connection Point
- (d) Work and or operation associated with equipment at the interface with the Distribution System.

3. Distribution Code and Other Documentation

The Distribution Code has been prepared by the ESB under the terms of the Electricity Regulation Act. This defines the technical aspects of the working relationship between DSO and all Users of the Distribution System, to ensure an efficient, co-ordinated and economical system for electricity Distribution. It also enables ESB to comply with its obligations under its Distribution Licence and the Grid Code.

The relationship between the Grid Code and Distribution Code is shown diagrammatically in Figure 1.

Users connected to the Distribution System shall comply with the relevant sections of the Distribution Code. The categories of Users of the Distribution System are described in Figure 2 and the sections of the Code which apply to each User is shown in Figure 3. Users shall also comply with the requirements of the Electricity Regulation Act and other relevant legislation, which from time to time comes into force. They shall also be required to enter into technical and other agreements. Customers and generators shall be required to have Connection Agreements with the ESB and Suppliers shall be required to enter into Use of System Agreements with the ESB.

There are a number of technical documents annexed to the Distribution Code. Users are bound to comply with the requirements of these documents as appropriate to their circumstances.

4. Structure of Distribution Code

The Distribution Code is divided into five parts as follows:

- (a) The Distribution General Conditions (DGC) sets out the legal framework guiding the operation of the Distribution Code.
- (b) The Distribution Planning Code (DPC) contains details of the standard of supply offered as well as the design principles to which the Distribution System is constructed. The DPC enables Users to obtain from DSO certain information on the Distribution System in certain circumstances.
- (c) The Distribution Connection Conditions (DCC) provides details of the technical and other requirements to be met by those requiring connection to the Distribution System. Special conditions pertaining to generators are contained in DCC 9.
- (d) The Distribution Operating Code (DOC) deals with the various operational matters affecting Users such as providing forecasts of demand, planning Distribution System outages, Generation outages, Transmission System outages, reporting of operational changes and events, Safety matters and procedures for dealing with emergency situations.
- (e) The Distribution Data Registration Code summarises in tabular form the data requirements under the Distribution Code.

5. Assumptions and Commentary

The Electricity Supply Board fully reserves its right to seek additions and amendments to the draft code at any time through the appropriate channels.

A thorough review of the provisions of this Distribution Code will be required when all other relevant documentation (licences, market protocols, other agreements etc.) are available and have been reviewed.

THE DISTRIBUTION CODE

GRID CODE AND DISTRIBUTION CODE BOUNDARIES

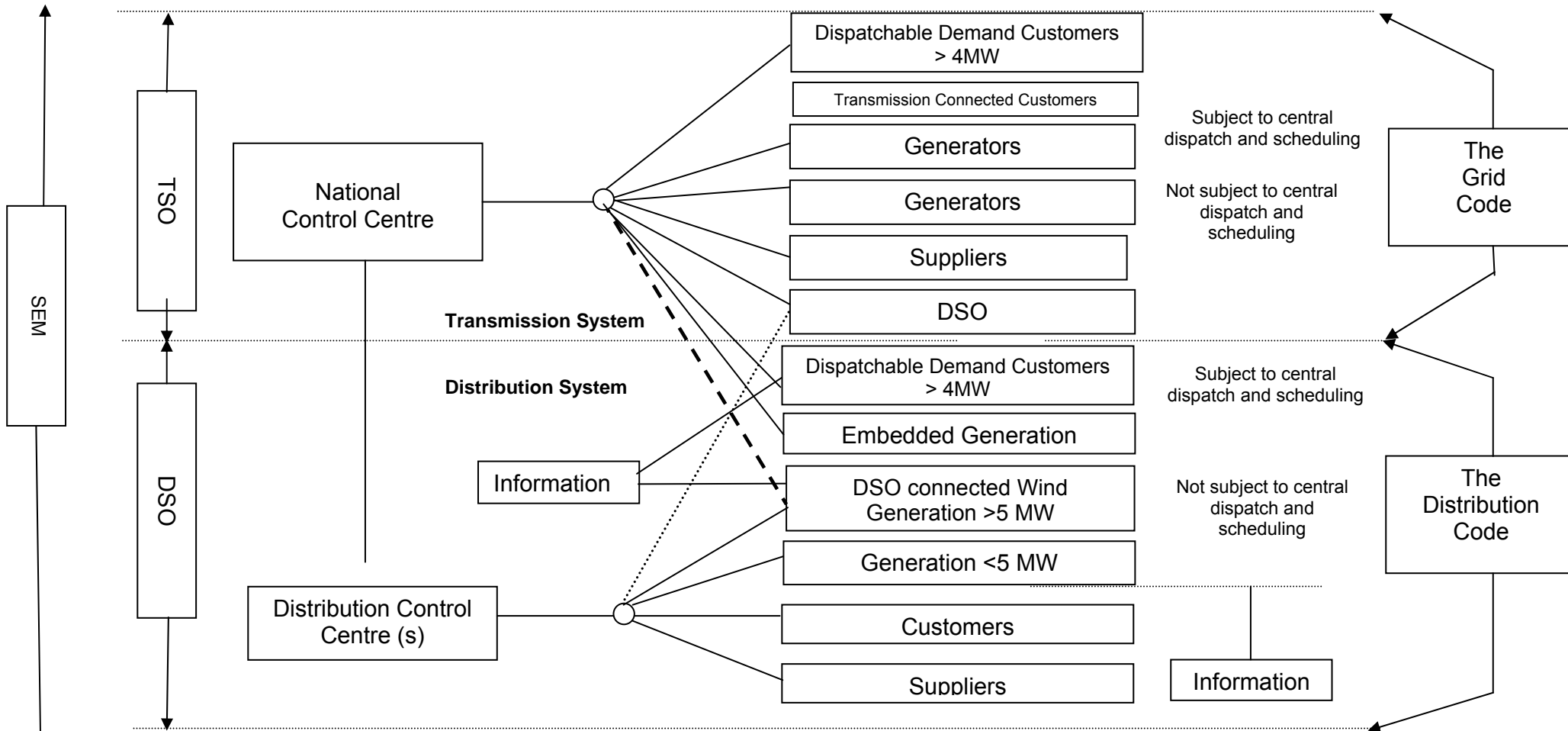

Figure 1

| |
|---|
| CATEGORIES OF USERS OF THE DISTRIBUTION SYSTEM |
|---|

- A1. Generating Plant >10MW and subject to central dispatch.
- A2. Generating Plant >2MW and not subject to central dispatch.
- A3. generators <2MW.
- A4. Customers with CHP or Customers with Auto-production.
- A5. Customers with stand-by generators.

- B1. Major Customers (customers connected at High Voltage).
- B2. Customers connected at Medium Voltage.
- B3. Industrial and commercial Customers connected at Low Voltage.
- B4. Domestic Customers.
- B5. Dispatchable Demand Customers

- C. Suppliers.

- D. The Distribution System Operator.

Figure 2

**SECTIONS OF THE DISTRIBUTION CODE APPLYING TO PARTICULAR
CATEGORIES OF USERS OF THE DISTRIBUTION SYSTEM**

CATEGORY OF USERS

| D Code Ref | A1 | A2 | A3 | A4 | A5 | B1 | B2 | B3 | B4 | B5 | C | D |
|------------|----|----|----|----|----|----|----|----|----|----|---|---|
| DGC | D | D | D | D | D | D | D | D | D | D | D | D |
| DPC1 | R | R | R | R | R | R | R | R | R | R | R | R |
| DPC2 | R | R | R | R | R | R | R | R | R | R | R | R |
| DPC3 | R | R | R | R | R | R | R | R | R | R | R | R |
| DPC4 | R | R | R | R | R | R | R | R | R | R | R | D |
| DPC5 | D | D | D | D | D | D | D | D | R | D | R | D |
| DCC1 | R | R | R | R | R | R | R | R | R | R | R | R |
| DCC2 | R | R | R | R | R | R | R | R | R | R | R | R |
| DCC3 | R | R | R | R | R | R | R | R | R | R | R | R |
| DCC4 | D | D | D | D | | D | D | D | D | D | R | D |
| DCC5 | D | D | D | D | | D | D | R | R | D | R | D |
| DCC6 | D | D | D | D | | D | D | D | D | D | R | D |
| DCC7 | D | D | D | D | | D | D | R | R | D | R | D |
| DCC8 | | | | | | D | D | D | D | D | R | D |
| DCC9 | D | D | D | D | D | D | D | D | | D | R | R |
| DCC10 | D | D | D | D | D | | | | | D | | D |
| DCC11 | D | D | D | D | D | | | | | D | R | D |
| DOC1 | | D | | | | D | D | | | D | | D |
| DOC2 | | D | D | D | | D | | | | D | | D |
| DOC5 | R | R | R | R | R | R | R | R | R | R | | D |
| DOC7 | D | D | D | R | | D | | | | D | | D |
| DOC8 | D | D | D | R | | D | | | | D | | D |
| DOC9 | D | D | D | R | | D | | | | D | R | D |
| DOC10 | D | D | D | D | D | D | D | D | D | D | R | D |
| DOC11 | D | D | D | D | D | D | D | D | D | D | R | D |
| DDRC | D | D | D | D | D | D | D | | | | | D |

■ Not Applicable

D Applicable with specific obligations

R Relevant for information but no specific obligations.

Note: Customers represented in Categories A4 and A5 must comply with the code sections relevant to that category and additionally to the relevant sections of the category of Customer to which they belong.

Figure 3

Distribution General Conditions

DGC DISTRIBUTION GENERAL CONDITIONS

DGC1 INTRODUCTION

DGC1.1 Whilst each Code in the Distribution Code contains the rules and provisions relating specifically to that Code, there are provisions which are of more general application. These are covered in the Code, Distribution General Conditions (DGC).

DGC2 OBJECTIVE

DGC2.1 The Distribution General Conditions contain provisions that are of general application to all provisions of the Distribution Code. Their objective is to ensure, to the extent possible, that the various sections of the Distribution Code apply consistently to all electricity customers.

DGC 3 SCOPE

DGC 3.1 The Distribution General Conditions apply to all Users.

DGC 4 ASSISTANCE IN IMPLEMENTATION

DGC4.1 The Distribution System Operator Licence imposes a duty upon the Distribution System Operator (DSO) to implement and enforce the Distribution Code. In order to do this the DSO may need access across boundaries, services, and facilities from Users or to issue instructions to Users, for example to isolate or disconnect Plant or Apparatus. It is considered that these cases will be exceptional and it is not, therefore, possible to envisage precisely or comprehensively what the DSO might reasonably require in order carry out its duty to implement and enforce the Distribution Code.

DGC4.2 All Users are required to abide by the Distribution Code and also to provide the DSO with such rights of access, services and facilities and to comply with such instructions as it may reasonably require to implement and enforce the Distribution Code.

DGC5 UNFORESEEN CIRCUMSTANCES

DGC5.1 If circumstances arise which the provisions of the Distribution Code have not foreseen, the DSO shall to the extent reasonably practicable in the circumstances, consult promptly and in good faith with affected Users in an effort to reach agreement as to what should be done. If agreement cannot be reached in the time available the DSO will determine what is to be done.

DGC5.2 Whenever the DSO makes a determination, it shall have regard, wherever possible to the views expressed by Users, and in any event, to what is reasonable in all the circumstances.

DGC5.3 Each User shall comply with all instructions given to it by the DSO following such a determination provided that the instructions are consistent with the then current technical parameters of the particular User's System registered under the Distribution Code. The DSO shall promptly refer all such unforeseen circumstances and any such determination to the Distribution Code Review Panel in accordance with DGC7.2.

DGC6 HIERARCHY

- DGC6.1 In the event of any conflict between the provisions of any direction of the Commission on the one hand and the provisions of the Distribution Code on the other, the provisions of such direction shall prevail (provided that such direction or ruling is binding upon the person to whom it is addressed).
- DGC6.2 In the event of any conflict between the provisions of the Distribution Code and any contract, agreement or arrangement between the DSO and a User, the provisions of the Distribution Code shall prevail unless the Distribution Code expressly provides otherwise.

DGC7 DISTRIBUTION CODE REVIEW PANEL

- DGC7.1 The DSO shall establish and maintain a Panel which, shall be a standing body, to carry out the functions referred to in DGC7.2
- DGC7.2 The Panel shall:
- (a) Keep the Distribution Code and its working under review.
 - (b) Review all suggestions for amendments to the Distribution Code which the Commission or any User may submit to the DSO for consideration by the Panel from time to time.
 - (c) Recommend to the DSO amendments to the Distribution Code that the Panel feels are necessary or desirable and the reasons for the recommendation.
 - (d) Issue guidance in relation to the Distribution Code and its implementation, performance and interpretation when asked to do so by any User.
 - (e) Consider what changes are necessary to the Distribution Code arising out of any unforeseen circumstances referred to it by the DSO under DGC5.
- DGC7.3 The Panel shall consist of:
- (a) Chairperson and two persons appointed by, and representing the DSO,
 - (b) One person appointed by and representing the Commission,
 - (c) One person representing the TSO,
 - (d) One person representing Generators with Generation,
 - (e) One person representing Major Customers,
 - (f) One person representing ESB Franchise Supply
 - (g) One representative of the Electro Technical Council of Ireland (ETCI).
 - (h) One representative of independent Suppliers.
- DGC7.4 The Panel shall establish and comply at all times with its own rules and procedures relating to the conduct of the business, such rules and procedures to be known as the Constitution and Rules of the Panel, which shall be approved by the Commission.
- DGC7.5 The DSO shall submit all proposed amendments to the Distribution Code (regardless of which party proposes such amendments) to the Panel for discussion.
- DGC7.6 The DSO shall, from time to time or at the behest of the Commission, having regard to the recommendations of the Panel, submit a revised Distribution Code to the Commission for approval.

DGC8 COMMUNICATIONS BETWEEN THE DSO AND USERS

DGC8.1 Unless otherwise specified in the Distribution Code the methods of operational communication and data transfer shall be agreed between the DSO and Users from time to time.

DGC9 EMERGENCY SITUATIONS

DGC9.1 Users should note that the provisions of the Distribution Code may be suspended, in whole or in part, pursuant to any directions given and / or orders made by the Minister under the provisions of the Act.

DGC10 CODE RESPONSIBILITIES

DGC10.1 The Distribution Code sets out the procedures and principles governing the relationship between the DSO and all Users of the Distribution System.

DGC11 DEROGATIONS

DGC11.1 If a User finds that it is, or will be unable to comply with any provision of the Distribution Code, then it shall without delay report such non-compliance to the DSO and shall, subject to the provisions of DGC11.2 make such reasonable efforts as are required to remedy such non-compliance as soon as reasonably practicable.

DGC11.2 Where the non-compliance is:

- (a) with reference to Plant and/or Apparatus connected to the Distribution System and is caused solely or mainly as a result of a revision to the Distribution Code; or
- (b) with reference to Plant and/or Apparatus which is connected, approved to connect, or for which approval to connect to the Distribution System is being sought;

and the User believes either that it would be unreasonable (including cost and technical considerations) to require it to remedy such non-compliance or that it should be granted an extended period to remedy such non-compliance it shall promptly submit to the Commission a request for a derogation from such provision in accordance with the requirements of DGC11.3 and shall provide the DSO with a copy of such application.

DGC11.3 A request for derogation from any provision of the Distribution Code shall contain:

- (a) the issue number and the date of the Distribution Code provision against which the non-compliance or predicted non-compliance was identified;
- (b) identification of the Plant and/or Apparatus in respect of which a derogation is sought and, if relevant, the nature and extent to which the non-compliance exists;
- (c) identification of the provision with which the User is, or will be, unable to comply;
- (d) the reason for the non-compliance; and
- (e) the date by which compliance will be achieved (if remedy of the non-compliance is possible) subject to DGC11.2 (b).

A standard Distribution Code Derogation Application form is included in Annex 2.

DGC11.4 If the DSO finds that it is, or will be, unable to comply with any provision of the Distribution Code, then it shall, subject to the remaining provisions of DGC11 make such reasonable efforts as are required to remedy such non-compliance as soon as reasonably practicable.

DGC11.5 In the case where the DSO requests a derogation, the DSO shall submit the information set out in DGC11.3 to the Commission.

DGC11.6 On receipt of any request for derogation, the Commission shall promptly consider such request and provided that the Commission considers that the grounds for the derogation are reasonable, the Commission shall grant such derogation unless the derogation would, or it is likely that it would have a material adverse impact on the security and stability of the Distribution System or imposes unreasonable costs on the operation of the Distribution System or Transmission System or on other Users. In its consideration of a derogation request by a User, the Commission may contact the relevant User and or the DSO to obtain clarification of the request to discuss changes to request. Where the derogation may have an impact on the Transmission System, the DSO shall liaise with the TSO prior to providing an assessment to the Commission.

Derogation from any provision of the Distribution Code shall contain:

- (a) The issue number and the date of the Distribution Code provision against which the derogation applies;
- (b) Identification of the provision with which the derogation applies;
- (c) Identification of the Plant and/or Apparatus in respect of which a derogation applies and, if relevant, the nature and extent to which the derogation applies including alternate compliance provision;
- (d) The reason for the non-compliance requiring derogation;
- (e) The date by which the derogation ends if compliance will be achieved, or by which such derogation expires.

DGC11.7 To the extent of any derogation granted in accordance with this DGC11, the DSO and/or the User (as the case may be) shall be relieved from its obligation to comply with the applicable provision of the Distribution Code and shall not be liable for failure to so comply but shall comply with any alternate provision as set forth in the derogation.

DGC11.8 DSO shall:

- (a) Keep a register of all derogations which have been granted, identifying the name of the person in respect of whom the derogation has been granted, the relevant provision of the Distribution Code and the period of the derogation; and
- (b) On request from any User, provide a copy of such register of derogations to such User.

DGC11.9 Where a material change in circumstance has occurred a review of any existing derogations, and any derogations under consideration, may be initiated by the Commission at the request of the Commission, DSO, or Users.

Distribution Planning Code

DPC DISTRIBUTION PLANNING CODE

DPC1 INTRODUCTION

- DPC1.1 The Distribution Planning Code (DPC) specifies the technical and design criteria and the procedures to be complied with by the DSO in the Planning and Development of the Distribution System. It also applies to Users in the planning and development of their installations in so far as they affect the Distribution System.
- DPC1.2 The Users' requirements may necessitate the reinforcement of, or an extension, to the Distribution System and for reinforcement of, or extension to, the relevant Transmission / Distribution interface capacity, such work being identified by the DSO or TSO as appropriate.
- DPC1.3 The time required for the planning and development of the Distribution System and any consequential requirement of the interface with the Transmission System, shall depend on the type and extent of the necessary reinforcement and / or extension work, the time required for obtaining Planning Permission and wayleaves, including any associated hearings, and the degree of complexity in undertaking the new work while maintaining satisfactory security and quality of supply.
- DPC1.4 Reference is made in the DPC to the DSO supplying information or advice to Users. For avoidance of doubt, unless the context otherwise requires, such information or advice shall be provided by the DSO as soon as practical following a request by the User (whether during the application for connection process or otherwise).

DPC2 OBJECTIVES

- DPC2.1 The objectives of the Distribution Planning Code are to:-
- (a) enable the Distribution System to be planned, designed and constructed to operate economically, securely and safely.
 - (b) facilitate the use of the Distribution System by others and to specify a standard of supply to be provided.
 - (c) provide sufficient information for a User to assess opportunities for connection and to plan and develop his or her installation so as to be compatible with the Distribution System.
 - (d) formalise System Planning data requirements.

DPC3 SCOPE

- DPC3.1 The Distribution Planning Code specifies the planning and design requirements for the Distribution System.
- DPC3.2 The Users to whom the Distribution Planning Code applies are those who use or intend to use the Distribution System and comprise the following:-
- (a) all Generators.
 - (b) all Customers connected to the Distribution System.
 - (c) Suppliers.
 - (d) Transmission System Operator

DPC4 DESIGN STANDARDS

DPC4.1 Frequency

DPC4.1.1 The frequency of supply is outside the control of the DSO however the expected standard frequency range is as follows:

The Transmission System Frequency is nominally 50 Hz:

- (a) Normal operating range: 49.8 to 50.2 Hz.
- (b) During system disturbances: 48.0 to 52.0 Hz.
- (c) During exceptional System disturbances 47.0Hz to 52.0Hz

DPC4.2 Voltage

DPC4.2.1 The Distribution System includes networks operating at the following nominal voltages:

TABLE 1 : DISTRIBUTION NOMINAL VOLTAGES

| | |
|---------------------|--|
| Low Voltage (LV) | 230 volts – phase to neutral 400 volts – phase to phase |
| Medium Voltage (MV) | 10,000 volts (10kV) 20,000 volts (20kV) |
| High Voltage (HV) | 38,000 volts (38kV) 110,000 volts (110kV) |

DPC4.2.2 The DSO shall operate the Distribution system so as ensure that the voltage at the *supply terminals*, as defined in EN 50160, complies with that standard. The low voltage range tolerance shall be 230V +/- 10%. The resulting voltage at different points on the system depends on several factors, but at the connection point with customers can be expected to be in accordance with Table 2 under steady state and normal operating conditions.

TABLE 2 – OPERATING VOLTAGE RANGE

| Nominal voltage | Highest voltage | Lowest voltage |
|-----------------|-----------------|---|
| 230V | 253V | 207 |
| 400V | 440V | 360 |
| 10kV | 11.1kV | Variable according to operating conditions. Information on particular location on request by user concerned |
| 20kV | 22.1kV | |
| 38kV | 43kV | |
| 110kV | 120kV | |

Higher maximum voltages can arise at the connection point with generators as per Table 5 in clause DCC10.5.

DPC4.2.3 The Distribution System and any User connections to that system shall be designed to enable normal operating Frequency and Voltages supplied to customers to comply with European Standard EN 50160:1995 “ Voltage characteristics of electricity supplied by public Distribution system”. Characteristics of the voltage, frequency, dips, interruptions, unbalance and harmonics are set out in this CENELEC approved standard. (Item 1, in Annex 1). It should be noted that the standard describes the main characteristics of the voltage that may be expected at the supply terminals under *normal* operating conditions.

DPC4.3 Earthing Requirements

DPC4.3.1 The treatment of the neutral is different for the various supply voltages. The present treatments are described below but these could change in the future.

DPC 4.3.2 The electrical installations of all new consumers connected at low voltage shall be protected by the TN-C-S system unless otherwise advised in line with the requirements of the National Rules for Electrical Installations - Electro Technical Council of Ireland (ETCI) (Item 14, Annex1).

DPC4.3.3 The main earthing terminal block shall be connected via an appropriately sized main protective conductor to the incoming ESB neutral conductor. An earthing conductor of appropriate size should be taken from the main earthing terminal to the consumer's earth electrode.

DPC4.3.4 For voltages above LV the following applies:

| <u>Voltage</u> | <u>Neutral Treatment</u> |
|----------------|--|
| 10kV | Isolated neutral throughout the country except in parts of Dublin and Cork City where it is either directly earthed or earthed through a 2 ohm or 4 ohm resistor so as to limit single-phase earth fault current to 1500 amps (typical). |
| 20kV | Earthed through a 20 ohm resistor which limits earth fault current to 500 amps. |
| 38kV | Earthed through an arc suppression coil (series inductance) at source 110kV substations. |
| 110kV | Effectively Earthed neutral system with an earth fault factor less than 1.4. |

DPC4.3.5 With the exception of LV networks where the TN-C-S system is permitted, multiple zero phase sequence paths are currently prohibited in the design of the Distribution System.

DPC4.4 Security of Supply

DPC4.4.1 The security standard for the Distribution System is set out in "Distribution System Security and Planning Standards" (Item 11, Annex 1).

DPC4.4.2 The DSO shall use reasonable endeavours to maintain a supply from the system. This cannot be ensured, since faults, planned maintenance and new works outages and other circumstances outside DSO's control can cause interruptions. On such occasions, the DSO shall use reasonable endeavours to restore the supply or connection as soon as practicable but shall be under no liability for any direct or indirect damage or associated loss incurred by the User.

DPC4.4.3 Restoration times are cited in the Customer Charter (Item 2, Annex 1). Guidelines for different outage types are as follows:

Fault Outages: The DSO shall endeavour to restore access to the system within twenty- four hours. In major storm conditions the outage duration may be longer and, in such circumstances, the DSO shall endeavour to keep the User advised of progress.

Planned Outages: The DSO shall endeavour to give three days notice of planned supply interruptions. In some situations - to facilitate emergency repairs or local outages affecting a small number of customers - shorter notice may be given.

Supply Curtailments: In some circumstances, it may be necessary to request customers to reduce load or to use standby supplies where appropriate. In these situations the DSO shall endeavour to maintain access to the System. In extreme cases where this may not be possible the DSO shall endeavour to provide two days notice to the User.

Load Shedding: In extreme situations there may be generation shortages and load shedding may be required. In these circumstances the DSO shall notify customers if possible but as this is an emergency situation this may not be possible.

DPC4.4.4 The DSO may disconnect Users under certain circumstances. These circumstances shall include:

- (a) Where the customer's installation or use of electricity is such as to interfere with the satisfactory operation of the Distribution or Transmission system or to cause electrical disturbance to other customers.
- (b) Where the DSO considers that the customer's installation is in a potentially dangerous condition.
- (c) Where alterations, repairs, renewal or maintenance of the Distribution System or DSO assets or means of connection require the de-energisation of the connection point.
- (d) Where a customer extends supply for use by another party whom the DSO considers to be a separate customer.
- (e) In any other circumstances in which discretion is necessary or appropriate to enable the DSO to comply with the Distribution Code and/or to operate the Distribution System in accordance with Good Industry Practice or is required by any law, direction, rule or regulation having the force of law.

DPC5 TRANSFER OF PLANNING DATA

DPC5.1 Planning Information to be provided by Users

DPC5.1.1 Users of the Distribution System shall provide sufficient planning data/information as can reasonably be expected to be made available, when requested by the DSO from time to time to enable the DSO to comply with the requirements under its Distribution Licence.

DPC5.1.2 Generators, Customers connected to the Distribution System including Dispatchable Demand Customers and Suppliers shall provide planning data for specific future time periods updated annually as necessary and including projected demand requirements, anticipated changes in maximum demand, or generating capacity, as appropriate. The data and timescales over which the data is required is given in Distribution Operating Code 1 (DOC1) and the associated data schedule is Schedule 2 of the Distribution Data Registration Code (DDRC).

DPC5.1.3 In addition to periodic updates of planning information a User shall give adequate notice of any significant change to their system or operating regime to enable the DSO to prepare its development plans and implement any necessary system modifications. In the event of unplanned changes in a User's System or operating regime a User shall notify the DSO as soon as is practically possible to ensure any necessary measures can be implemented.

DPC5.1.4 Users shall also provide details of reactive compensation plant directly or indirectly connected to the Distribution System other than at Low Voltage, including its rating and operational control.

DPC5.1.5 Users may be required to provide the DSO with detailed data relating to the interface between their System

and that of the Distribution System covering circuit parameters, switchgear and protection arrangements of Equipment directly connected to or affecting the Distribution System to enable the DSO to assess any implications associated with these points of connection.

DPC5.2 Information to be Exchanged

DPC5.2.1 On the request of a User, the DSO shall provide such information, as may be reasonably required, on the design and other characteristics of the Distribution System.

DPC5.2.2 Where the DSO proposes to make certain modifications to its system or where it has received information from a User under DPC5.1 above, which may impact on other User Installations then the DSO will notify Users of the proposal, subject to any constraint of confidentiality or timing.

DPC5.2.3 The DSO shall provide information on request to Users regarding the local network conditions to enable them to determine their protection requirements.

DPC5.2.4 Where the Users installation is connected to the busbars of the Distribution System sufficient details may need to be exchanged with respect to User / the DSO Ownership Boundary to enable an assessment to be made of transient overvoltage effects. The request for information may be initiated by either the DSO or the User.

DPC5.2.5 Information may be exchanged between the DSO and the User on fault infeed levels at the feeding busbar or point of connection to the Distribution System as appropriate, in the form of

- three phase and single phase earth short circuit infeed.
- The X/R ratio under three phase fault conditions.

DPC5.2.6 Information shall be exchanged between the DSO and User on Demand Transfer Capability where the same demand can be supplied from alternate User points of supply. This shall include the proportion of Demand normally fed from each point of supply and the arrangements (manual or automatic) for transfer under planned/fault outage conditions.

DPC5.3 Planning Studies

DPC5.3.1 In order to facilitate connections to the Distribution System the DSO shall prepare on request a study showing the implications of a connection at a particular point on the system.

DPC5.3.2 Under the terms of the Distribution Licence a reasonable charge may be levied by the DSO for the planning study. Details of these charges are set out in "Guide to the Process for connection to the Distribution System" (Item 3, Annex 1).

- DPC5.3.3 Users or potential Users shall provide to the DSO information regarding the proposed facility including load details, interface arrangements, proposed connection point and import / export requirements.
- DPC5.3.4 The studies shall normally be prepared within 28 days after the date of receipt of the information or the agreement of the person making the request to pay the cost of the study, whichever is the longer. In the case of Generators and Major Customers seeking connection, depending on the nature and complexity of the request, this period may extend up to 100 days or a further 28 days from the receipt of planning information from the TSO whichever is the greater.
- DPC5.3.5 Details of the procedures for application for connection to the Distribution System are contained in "Guide to the Process for connection to the Distribution System" (Item 3, Annex 1).
- DPC5.3.6 Rules applied by the DSO in determining the connection requirements are outlined in the "Distribution System Security & Planning Standards" (Item 11, Annex 1).
- DPC5.3.7 Where such information is available the DSO shall provide on request a statement of present and future circuit capacities, forecast power flows and loadings on part or parts of the Distribution System specified in the request and shall include fault levels at each Distribution node covered by the request. The DSO may levy a charge for the provision of this statement as approved by the Commission for Energy Regulation (CER) on account of the reasonable costs incurred by the DSO in preparing this statement. The statement shall be prepared within 28 days after the date of receipt of the information or the agreement of the person making the request to pay the cost of the statement, whichever is the longer. In the case of Generators and Major Customers seeking connection this period may extend up to 110 days depending on the nature and complexity of the request.
- DPC5.3.8 The dates given in this DPC 5.3 are target dates only and do not constitute a legal commitment. The DSO shall however use reasonable endeavours to abide by them.

Distribution Connection Conditions

DCC DISTRIBUTION CONNECTION CONDITIONS

DCC1 INTRODUCTION

DCC1.1 It is necessary to require certain minimum technical, design and operational criteria to be met by Users' Plant and Apparatus in order to maintain, insofar as is permitted by Good Industry Practice, stable and secure operation of the Distribution System for the benefit of all Users and for the protection of the Distribution System and Users' Plant and Apparatus directly connected to the Distribution System.

DCC1.2 The Distribution Connection Conditions establish certain principles and standards relating to the provision of the connection, method of connection, and technical and performance standards.

DCC1.3 The Distribution Connection Conditions specifies the information to be provided by Users to ensure that adequate provision can be made by the DSO for new connections or increases in existing load. It also applies to Generators who operate in parallel with the Distribution System, where a connection is required.

Prospective Users shall provide to the DSO in good time all the details set out in this section.

DCC1.4 In conjunction with the Connection Conditions, there are Connection Agreements, which are bilateral agreements between the DSO and each User, and which contain the detail specific to each User's connection to and use of the Distribution System. The Connection Agreement requires the User and the DSO to comply with the terms of the Distribution Code.

DCC2 OBJECTIVE

DCC2.1 The Connection Conditions define the minimum standards for the method of connection to the Distribution System and the technical, design and operational standards to which Users connecting to the Distribution System shall comply.

DCC2.2 The Connection Conditions specify the technical arrangements required at the Ownership Boundary between the Distribution System and the Installation of the User and is applicable at all voltage levels covered by the Distribution Code.

DCC2.3 The Connection Conditions outline the types of signals and indications that will be required to be made available to the DSO by each User.

DCC3 SCOPE

DCC3.1 The Connection Conditions apply to the DSO and to all Users connected to or planning a connection to the Distribution System.

DCC4 INFORMATION REQUIRED FOR CONNECTION

DCC4.1 For connections at Low Voltage it is possible in most cases to assess whether a proposed connection is acceptable, and to determine the necessary supply arrangements, from analysis of the following data:

- (a) Maximum kVA requirements.
- (b) Type and electrical loading of equipment to be connected, such as number and size of motors, cookers, showers, space and water electrical heating loads and nature of disturbing loads e.g. welding equipment.
- (c) The date when connection is required.

If a preliminary examination of this data indicates that more detailed information is reasonably required then it shall be provided to the DSO upon request.

DCC4.2 Information Requirements and timeframes for quotation and connection are provided in "Guide to the Process for connection to the Distribution System" (Item3, Annex 1). This also contains the application forms that Users requiring a connection or extension to the Distribution System are obliged to complete. Copies of this document are available on request from the DSO.

DCC4.3 For connections at High and Medium Voltages the provisions of DCC4.1 also apply. Additionally, the following information may be required as detailed in the Distribution Data Registration Code (DDRC) Schedule 5.

- (a) All types of Demand
 - (i) Maximum Active Power requirements.
 - (ii) Maximum and Minimum Reactive Power requirement.
 - (iii) Type of load and control arrangements (e.g. type of motor start, controlled rectifier or large motor drives).
 - (iv) Maximum load on each phase.
 - (v) Maximum harmonic currents that may be imposed on the Distribution System.
 - (vi) Details of cyclic load variations or fluctuating loads (as below).

(b) Disturbing Loads

Comprehensive schedule of installed new equipment including details of disturbing loads. These are loads which have the potential to introduce harmonics, flicker or unbalance to the system. This could adversely affect the supply quality to other customers. Disturbing loads could be non-linear loads, power converters / regulators and loads with a widely fluctuating demand. The type of load information required for motive power loads, welding equipment, harmonic producing / non linear loads and generating equipment can be obtained from the DSO on request.

In the case of compensating equipment associated with disturbing loads, details and mode of operation to be provided so as to ensure compliance with emission limits specified in DCC6.8.3.

(c) Fluctuating Loads

Details of cyclic variation, and where applicable the duty cycle, of active Power (and Reactive Power if appropriate), in particular:-

- (i) the rates of change of Active Power and Reactive Power, both increasing and decreasing;
- (ii) the shortest repetitive time interval between fluctuations in Active Power and Reactive Power; and
- (iii) the magnitude of the largest step changes in Active Power and Reactive Power, both increasing and decreasing

DCC4.4 In some cases, more detailed information may be required to permit a full assessment of the effect of the User's load on the Distribution System. Such information may include an indication of the pattern of build up of load and a proposed commissioning programme. This information shall be specifically requested by the DSO when necessary and shall be provided by the User within a reasonable time.

DCC4.5 Users shall contact the DSO in advance if it is proposed to make any significant change to the connection, electric lines or electric equipment, install or operate any generating equipment or do anything else that could affect the Distribution System or require alterations to connection.

DCC4.6 Users shall provide to the DSO any information reasonably required by the DSO about the nature, or use by the User, of electrical equipment on the Users' premises.

DCC5 CONNECTION ARRANGEMENTS

DCC5.1 Connection Voltage

DCC5.1.1 During the application for connection process the DSO shall, in consultation with the User, specify the voltage level to which a User will be connected in accordance with normal practice for the type of load to be supplied and network characteristics.

DCC5.1.2 Generally, the voltage level will be the minimum nominal voltage in standard use on the System, (subject to DCC5.1.3), assessed against:

- (a) satisfactory operation of the installation
- (b) isolation of disturbance from other customers
- (c) lifecycle costs
- (d) cost of connection

DCC5.1.3 Ongoing development of the Distribution System is leading to a newer and more efficient voltage regime. The 10kV nominal system is being converted progressively to 20kV while the 38kV system is being curtailed in favour of the 110kV and 20kV systems. Because of this:

- Connections at 10kV shall have provision for conversion to 20kV at the same time as the local network is being converted.
- The DSO shall advise prospective Customers at the time of application if there are firm plans to change from 38kV to 110kV or 20kV operation at a future date. In such cases Customers shall make provision for such a changeover.

DCC5.1.4 The DSO may, on occasion, specify a different connection voltage from normal in order to avoid potential disturbances caused by the User's Apparatus to other Users of the Distribution System or for other technical reasons or may agree alternative methods for minimising the effects of disturbing loads.

DCC5.2 Information provided by DSO

Based on the information provided by the User for a connection to the Distribution System, the DSO shall prepare a statement containing as many of the following elements as are necessary for, or relevant to, the proposed installation:

- (a) Nominal voltage at which connection will be made
- (b) Method of connection, extension and/or reinforcement details
- (c) The normal impedance to source at the point of connection
- (d) Method of earthing
- (e) Maximum Import Capacity
- (f) Individual customer limits relating to:
 - (i) Harmonic Distortion
 - (ii) Voltage Flicker
 - (iii) Unbalance
- (g) Expected lead time of providing connection (following formal acceptance of terms for Supply).
- (h) Cost of connection

DCC5.3 Ownership Boundaries

DCC5.3.1 The point or points at which supply is given or taken between the Distribution System and User's installation shall be agreed between the DSO and the User as required.

DCC5.3.2 For LV supplies the DSO's responsibility extends up to the Customer's Connection Point which is normally:

- (a) In major installations:

At the main fuses on the Supply side of Customer's main circuit breaker.
- (b) In Single Domestic Premises at the Connection Point of customers tails on the Supply side of special isolator.

The National Code of Practice for Customer Interface (Item 4, Annex 1) contains the rules for interface connections and Users shall comply with its provisions.

DCC5.3.3 For High Voltage supplies the ownership boundaries shall be subject to specific agreement between the parties in each case. Changes in the Boundary arrangements proposed by either party shall be agreed in advance.

DCC5.3.4 All equipment at the Ownership Boundary shall meet the design principles contained in DPC4 and DCC5. Connections for entry to and exit from the Distribution System shall incorporate a means of disconnection of the User's installation by the DSO.

DCC5.3.5 The respective ownership of Plant or Apparatus shall be recorded in a written agreement between the DSO and the User or in diagramatic form, as required. In the absence of a separate agreement between the parties to the contrary, construction, control, operation and maintenance responsibilities follow ownership.

DCC6 TECHNICAL REQUIREMENTS FOR CONNECTIONS

DCC6.1 Connection Standards

DCC6.1.1 A connection to the Distribution System may be by means of an overhead line, an underground cable or a combination of both. The network configuration at the Connection Point may take a number of forms suitable to the nature of the load and network arrangements.

DCC6.1.2 All equipment in an installation connected to the Distribution System shall be designed, manufactured, tested and installed in accordance with all applicable statutory obligations and shall conform to the relevant Electro Technical Council of Ireland (ETCI), CENELEC or IEC standards current at the time of the connection of the installation to the Distribution System.

DCC6.1.3 If there is no relevant European specification, such other relevant standard which is in common use in the European Union, as current at the date of the User's applicable Connection Agreement, shall apply. If the DSO considers it necessary, however, the DSO may notify Users that supplemental specifications and/or standards shall be complied with, in which case User Plant and Apparatus shall so comply.

DCC6.1.4 All equipment in an installation connected to the Distribution System shall be suitable for use at the operating frequency of the Distribution System and at the voltage and short-circuit rating of the Distribution System as shown in Table 3, at the Connection Point. The DSO may require certification that the equipment has been designed and installed in a satisfactory manner. The DSO may also seek evidence that the equipment has been tested for conformance with the standards.

DCC6.1.5 For Users connected at Low Voltage, installations shall comply with the National Rules for Electrical Installations produced by the ETCI (Item 14, Annex 1) and any other rules and regulations issued by ETCI from time to time. Users complying with these rules and regulations shall be deemed to comply with the requirements of the Distribution Code as regards design and safety. The DSO may seek evidence that the equipment has been tested for compliance with standards.

DCC6.1.6 Before entering into a connection agreement it will be necessary for the DSO to be reasonably satisfied that the User's System at the boundary with the Distribution System shall comply with the appropriate requirements of the Distribution Code and when applicable the National Code of Practice for Customer Interface.

DCC6.2 Protection Requirements

DCC.6.2.1 Users shall ensure that faults in the User's Plant and Apparatus do not unreasonably cause disturbances to the Distribution System or to other Users. Without limiting this obligation, a User shall prior to connection of the User's Installation to the Distribution System, install the protection equipment specified in DCC6.2.4.

DCC6.2.2 Faults on the Distribution System can cause damage to User's Plant and Apparatus. These faults could result in a loss of a phase, over Voltage, or under Voltage. The User shall take account of the established practices of the particular network to which a connection is to be made, and ensure that protection installed is compatible with that used by the DSO. The adequacy of the protection installed by the User is the User's responsibility.

DCC6.2.3 The User's Protection arrangements at the Ownership Boundary, including types of Equipment and Protection settings, shall be compatible with existing system conditions and the Distribution System protection practice as specified by the DSO at the time of application. In particular

- (a) The maximum clearance times (from fault current inception to arc extinction) shall be within the limits established by the DSO in accordance with Protection and Equipment short circuit rating policy adopted for the Distribution System.
- (b) In connecting to the Distribution System the User should be aware that fast and slow speed automatic reclosing is a feature of Power System operation. This is characterised by sudden de/re-energisation of the power supply. Dead times are typically 0.3s, 1s and 10s at Medium Voltage and 3s and 60s on 38kV systems. All tripping and high speed reclosing on the 110kV system is three poles with a dead time of approximately 400mS.
- (c) Users should also be aware that disconnection of one or two phases only of a three phase system may be effected by Distribution Protection arrangements for certain types of faults.

DCC6.2.4 The minimum protection required for a User Installation connected to the Distribution System will vary according to type, size, method of connection (loop/tail/tee) and earthing of the User System. Low Voltage Customers shall comply with The National Code of Practice for Customer Interface (Item 4, Annex 1). Other User installations will vary. It is anticipated that a new connection may require all or some of the following protection facilities:

- (a) Three phase overcurrent
- (b) Earth fault protection (suited to the local supply system)
- (c) Distance
- (d) Intertripping
- (e) Other

DCC6.2.5 Where interface circuit breakers are used they shall be fitted with relays of a type acceptable to the DSO. These relays shall have three phase overcurrent elements and one earth fault element and shall have time-current characteristics complying with standard types A, B and C of IEC 255. Maximum permissible relay settings at the ownership boundary, necessary to provide selectivity with Distribution equipment, will be provided by the DSO, and these settings may be reviewed at any time in the future by the DSO. Distribution protection aims to minimise the impact of faults including voltage dip duration and must not be adversely affected by customer's protection limitations.

- (a) In order to ensure satisfactory operation of the Distribution System, Protection systems, operating times, discrimination, and sensitivity at the Ownership boundary shall be agreed between the DSO and the User during the application for connection process, and may be reviewed from time to time by the DSO.
- (b) In order to cover a Circuit Breaker, or equipment having similar function, failing to operate correctly to interrupt fault current on the System, back-up protection by operation of other circuit breakers or equipment having a similar function shall normally be provided.
- (c) Unless the DSO advises otherwise, it is not acceptable for Users to limit the fault current infeed to the Distribution System by the use of Protection and associated Equipment if the failure of that Protection and associated Equipment to operate as intended in the event of a fault, could cause Equipment owned by the DSO to operate outside its short-circuit rating.

DCC6.2.6 Protection relays shall be commissioned on site by the User who shall ensure that the settings are below the maximum permitted levels. In certain cases the DSO may wish to witness these tests and it shall be the responsibility of the User to ensure that sufficient notice is given to the DSO in such cases. Users shall ensure that the protection settings remain below the maximum permitted levels. This may require regular testing of the relays.

DCC6.3 Earthing

DCC6.3.1 Earthing of the part of the User's Installation that is connected to the Distribution System shall comply with the requirements of DPC4.3.

DCC6.3.2 The arrangements for connecting the User's Installation with earth shall be designed to comply with relevant ETCI requirements. For Medium Voltage Users and for High Voltage Users "Conditions Governing Connection to the Distribution System: Connections at MV and 38kV and Generators at LV, MV and 38kV" (Item 7, Annex 1) applies.

DCC6.3.3 The method of earthing the Distribution System, for example, whether it is connected solidly to earth or through an impedance, shall be advised by the DSO. The specification of associated equipment shall meet the voltages which will be imposed on the Equipment as a result of the method of earthing.

DCC6.3.4 Users shall take precautions to limit the occurrence and effects of circulating currents in respect of neutral points connected with earth where there is more than one source of energy.

DCC6.4 Voltage Regulation and Control

Extensions or connections to the Distribution System shall be designed such that they do not prevent the necessary control of voltage on the Distribution System. Information on the voltage regulation and control arrangements shall be made available by the DSO if requested by the User.

DCC6.5 Short-Circuit Levels

DCC6.5.1 The short circuit rating of User's Equipment at the connection point shall not be less than the design Fault Level of the Distribution System as shown in Table 3 below. The choice of Equipment for connection at Low Voltage may take into account attenuation in the service lines. The DSO shall take into account the contribution to Fault Level of the User's connected System and Apparatus in the design of its System.

TABLE 3: SHORT CIRCUIT RATINGS

| Connection Voltage | Short Circuit Level (RMS Symmetrical) Normally | Short Circuit Level (RMS Symmetrical) Certain Designated Areas |
|--------------------|--|--|
| LV (Domestic) | 9.0kA | |
| LV (Ind/Comm) | 37.0kA | |
| 10kV | 12.5kA | 20kA |
| 20kV | 12.5kA | 20kA |
| 38kV | 12.5kA | 20kA |
| 110kV | 26.0kA | 31.5kA |

In certain 220kV/110kV substations at 110kV busbars the design short circuit level is 40KA.

DCC6.5.2 The User's incoming supply shall be controlled by a main circuit breaker which shall be in accordance with a recognised international standard acceptable to the DSO.

DCC6.6 Insulation levels

DCC6.6.1 The design of an operators equipment connected to the Distribution System shall be such as to enable it to withstand, under test, the AC and impulse (1.2/50 μ S) voltages indicated in Table 4 below.

TABLE 4 : INSULATION LEVELS

| Voltage of Equipment | AC Withstand Level | Impulse Level |
|----------------------|--------------------|---------------|
| LV | 3kV | |
| 10kV | 50kV | 125kV |
| 20kV | 50kV | 125kV |
| 38kV | 95kV | 250kV |
| 110kV | 230kV | 550kV |

DCC6.7 Capacitive and Inductive Effects

DCC6.7.1 The User shall, when applying to make a connection, provide the DSO with information as detailed in DPC4. Details shall be required of any capacitor banks and reactors connected at High Voltage, which could affect the Distribution System and which it is proposed to connect if agreed with the DSO. When requested by the DSO, details shall also be provided of distributed circuit capacitance and inductance. Sufficient detail is required for the following:-

- (a) to verify that controlling Equipment of the Distribution System is suitably rated;
- (b) to show that the performance of the Distribution System will not be impaired;
and
- (c) to ensure that arc suppression coils on the Distribution System neutral are correctly installed and operated.

DCC6.8 Voltage Disturbances

DCC6.8.1 Users of the Distribution System should not generate voltage disturbances at a level that would affect other Users. Users should in their own interest select equipment that is capable of functioning satisfactorily in the presence of disturbances at the levels permitted by EN50160.

DCC6.8.2 It is a condition of connection that equipment connected directly or indirectly to the Distribution System shall conform to the requirements of EU Directive 89/336/EEC (the EMC Directive) as amended.

DCC6.8.3 Loads and installations shall comply with the following emission limits. Special conditions for generators are outlined in DCC10.6.1

(a) Voltage Flicker

(i) Frequency of occurrence: 0.22 per min – 600 per min

| Voltage Level | P _{st} | P _{lt} |
|---------------|-----------------|-----------------|
| 38kV, MV, LV | 0.7 | 0.5 |

P_{st}: Short Term Flicker Severity - an index of visual severity evaluated over a 10 minute period.

P_{lt}: Long Term Flicker Severity - an index of visual severity evaluated over a 2 hour period.

(ii) Frequency of occurrence: 0.02 per min – 0.22 per min

Magnitude of up to 3% is permitted.

(iii) Frequency of occurrence: =< 0.02 per min

Magnitude of up to 5% is permitted.

(b) Harmonic Distortion

(i) Individual Harmonic Orders:

% Harmonic Voltage Distortion
(rms voltage as a % of rms value of the fundamental component)

| Harmonic Order | LV | MV | 38kV |
|----------------|------|------|------|
| 2 | 0.70 | 0.50 | 0.25 |
| 3 | 0.75 | 0.50 | 0.25 |
| 4 | 0.70 | 0.50 | 0.25 |
| 5 | 2.00 | 1.00 | 0.50 |
| 6 | 0.50 | 0.50 | 0.30 |
| 7 | 2.00 | 1.00 | 0.50 |
| 8 | 0.50 | 0.50 | 0.30 |
| 9 | 0.50 | 0.50 | 0.25 |
| 10 | 0.50 | 0.75 | 0.25 |
| 11 | 1.50 | 1.50 | 0.75 |
| 12 | 0.50 | 0.50 | 0.30 |
| 13 | 1.50 | 1.50 | 0.75 |
| 14 | 0.50 | 0.50 | 0.50 |
| 15 | 0.50 | 0.75 | 0.25 |
| 16 | 0.75 | 0.75 | 0.25 |
| 17 | 0.75 | 0.75 | 0.50 |
| 18 | 0.50 | 0.50 | 0.25 |
| 19 | 1.00 | 0.50 | 0.25 |

(ii) Total Harmonic Distortion

| Voltage Level | % Harmonic Voltage Distortion |
|---------------|-------------------------------|
| LV | 2.5 |
| MV | 2.0 |
| 38kV | 1.5 |

(c) Unbalance

The unbalance caused by the connection of an individual installation shall not exceed 1.3% at the Point of Common Coupling (PCC).

DCC6.8.4 Under fault and circuit switching conditions the rated frequency component of voltage may fall or rise transiently. The rise or fall in voltage will be affected by the method of earthing of the neutral point of the Distribution System and voltage may fall transiently to zero at the point of fault. Sections 2 and 3 of EN 50160, as amended from time to time, contains additional details of the variations and disturbances to the voltage which shall be taken into account in selecting Equipment from an appropriate specifications for installation on or connected to the System.

DCC6.9 Power Factor and Phase Balance

DCC6.9.1 The customer shall take all reasonable steps to operate the Plant and the Facility to keep the power factor of the total load at the Connection Point for imported electricity between 0.90 lagging and unity and for exported electricity between 0.95 lagging and unity. Wind generators must keep power factor between 0.92 and 0.95 lagging. For the purpose of this code, lagging power factor refers to the absorption of reactive power. These are minimum requirements. In certain instances specific requirements may apply in order to ensure that the DSO can comply with the requirements of the Grid Code.

DCC6.9.2 DSO Phase Balance requirements are covered in EN50160.

DCC7 METERING / TELEMETRY

DCC7.1 The User may be required to provide such voltage, current, frequency, Active Power and Reactive Power pulses that are considered necessary by the DSO to ensure adequate System monitoring. Details will be specified in the User's Connection Agreement.

DCC7.2 Centrally Dispatched Users shall provide signals to the TSO as required by the Grid Code.

DCC7.3 If it is agreed between the parties that the DSO shall control the switchgear on the User's System, the DSO shall install the necessary telecontrol outstation. Notwithstanding the above, it shall be the responsibility of the User to provide the necessary control interface for the switchgear of the User which is to be controlled.

DCC7.4 Metering principles applying to certain Users connected to the Distribution System are specified in the Metering Code.

DCC7.5 Specific metering arrangements depend on the load type, size and nature of the installations being connected. A consensus document has been agreed between the DSO and Consultants / Contractors Associations and this comprises the 'National Code of Practice for Customer Interface' (Item 4, Annex 1).

DCC7.6 Personnel carrying out design or installation work for the customer / operator interface with the DSO should familiarise themselves with and work to this code. Unusual situations may arise which are not covered by the code. In such circumstances the DSO will be available to deal with queries.

DCC8 SPECIFIC ARRANGEMENTS

DCC8.1 The specific arrangements for connection, including substation layout requirements, User Equipment and Tariffs and Metering are set out clearly in a number of documents. Annex 1 contains a list of these documents which are available from the DSO on request of the User. Users must comply with the provisions of the documents relevant to their installations.

- (a) "Conditions for Connection to the Distribution System" and "General Conditions for Connection of Industrial and Commercial Customers and Generators to the Distribution System" (Items 5 & 6, Annex 1)

- (b) Conditions Governing Connection to the Distribution System: Connections at MV and 38kV and Generators at LV, MV and 38kV (Item 7, Annex 1)
- (c) General Specification for MV Substation Buildings (Spec. No.13320). (Item 8, Annex 1)

DCC8.2 Service standards relating to low voltage (230 / 400V) supplies are covered in:

- (a) Customer Charter- ESB Networks (Item 2, Annex 1)

The rules for low voltage supplies are published in somewhat greater detail in three other documents:

- (b) "Conditions for Connection to the Distribution System" and "General Conditions for Connection of Industrial and Commercial Customers and Generators to the Distribution System" (Items 5 & 6, Annex 1)
- (c) Domestic Supply: Procedures and Conditions for Supply to New House from Overhead Networks. (Item 9, Annex 1)
- (d) Domestic Supply: Specification of Requirements for Supply to Housing Schemes. (Item 10, Annex 1)

Please note that all the documents referred to in DCC8 are subject to updating and change. At the time of any proposed new connection, only the up-to-date versions of these documents should be used.

DCC9 ADDITIONAL REQUIREMENTS FOR ALL 110KV CONNECTED USERS

DCC9.1 Plant Designations

DCC9.1.1 The name of the User site shall be designated by the User and subsequently approved by the DSO.

DCC9.1.2 The designation and proposed nomenclature of User Plant and Apparatus connected to Distribution System shall be in accordance with the DSO standard practice which, in particular, is designed to ensure that designation and nomenclature avoids confusion. The User shall notify the designation and proposed nomenclature of Users' Plant and/or Apparatus to the DSO who may, if the DSO determines that such proposed designation may lead to confusion or does not conform to the DSO standard practice, notify a substitute designation which shall apply to such User Plant and/or Apparatus.

DCC9.1.3 The DSO standard practice currently requires that, unless otherwise agreed with the DSO, the standards outlined in schedule 6 shall apply.

DCC9.1.4 Every User shall be responsible for the provision, erection and maintenance of clear and unambiguous labelling showing the designation and nomenclature of its Plant and Apparatus at the User Site.

DCC9.2 Earthing

DCC9.2.1 The earthing of all Users Plant and Apparatus and provision of an earthing System shall as a minimum requirement be in accordance with the recommendation contained in the "Guide for Safety in Alternating Current Substations", ANSI/IEEE No. 80 1986

- DCC9.2.2 The DSO shall consult with each User regarding the specification of the earthing grid to be provided.
- DCC9.2.3 Each User's earth disconnects must be earthed directly to the main station earth grid.
- DCC9.2.4 The User will be obliged to certify (by a competent body) that the remote earths have been isolated from the User's site plus any other affected third party sites and that adequate precautions shall be taken by the User to ensure that dangerous grid potential rises are not transferred outside the earthing zone. The Distribution Station cannot be energised until this certification has been received by the DSO.
- DCC9.2.5 Each User's earthing system shall be bonded to the Distribution station earth grid so that both earthing systems are effectively integrated.

DCC9.3 Design

- DCC9.3.1 User Plant and Apparatus shall be designed with the following minimum capabilities:

| Parameter (minimum) | mm |
|---|-----------|
| Clearance outdoor in air of live metal parts phase to earth | 1100 |
| Height of live parts above pedestrian passageways | 3400 |
| Height of bottom of unscreened live bushings above ground | 2300 |
| Height of live conductors above roadways | 8000 |

- DCC9.3.2 LV cables and wiring
- DCC9.3.2.1 All multi-core control and protection cables shall be provided with a suitable metallic screen. Facilities for earthing these screens at the base of cabinets shall be provided.
- DCC9.3.2.2 LV supply cable and auxiliary wiring shall be routed from the Distribution Station to each User's control building through a mutually agreed cable corridor. The cables will be laid in concrete troughs with reinforced concrete covers, or as mutually agreed, to the User's Marshalling rack, which will be situated near the Distribution Station.
- DCC9.3.3 Locking
- DCC9.3.3.1 The facility to lock in the open/closed position and interlocking facilities shall be provided by each User on appropriate disconnects and/or circuit breakers (with withdraw facilities) in order to ensure that the incoming feeder(s) to the facility can be safely isolated when required by the DSO. The specific details of this requirement will be outlined at the design phase.

- DCC9.3.4 110kV step up transformers
- DCC9.3.4.1 Generators shall provide on-load tap-changing (OLTC) facilities for all Generator Transformers. Demand User are advised to provide on-load tap-changing (OLTC) facilities for all 110kV step up Transformers. All Users shall liaise with the DSO on the design specification for the performance of the tap-changing facility on 110kV Connector Transformers.
- DCC9.3.4.2 Generator Transformer windings shall be connected in star (with the star point or neutral brought out) on the higher Voltage side and in delta on the lower Voltage side.
- Other 110kV step up transformers may be connected either:
- a. in delta on the lower voltage side and in star (with the star point or neutral brought out) on the higher Voltage side; or
 - b. in star on both higher and lower Voltage sides with a delta tertiary winding provided.
- DCC9.3.4.3 Provision should be made for the earthing of the neutral of each Transformer connected to the 110kV System by bringing out the neutral and ensuring that the insulation is such that the transformer can be operated unearthed.
- DCC9.3.4.4 The DSO will provide the facility for the tripping of the 110kV step up Transformer HV circuit breaker from the User's transformer protection.

DCC9.4 User Protection

- DCC9.4.1 Every User shall, acting in accordance with Good Industry Practice, be responsible, insofar as is reasonably practicable, for ensuring that faults on Plant and Apparatus cause minimal disturbance to the Power System. Faults on Plant and/or Apparatus connected to the Distribution System should be cleared as soon as possible with no deliberate time delay introduced and in any event should be cleared within a maximum time of 120 milliseconds on the 110kV system.
- DCC9.4.2 In order to ensure the secure operation of the Distribution System and correct co-ordination and discrimination between faults on the Transmission System and Distribution System and the User's system, settings for the User's protection Systems that may have an operational effect, shall be notified to the DSO and it will be necessary for the DSO to, and the DSO may, prohibit the settings of some User protection systems within certain ranges. Protection system where such limitations will apply include, but are not limited to:
- a) Generation Unit under-frequency, over-current or distance protection;
 - b) Transformer over-fluxing, over-current or distance protection
 - c) Loss-of-mains protection
- A mechanism for the notification and where applicable approval and determination, of such settings will be set out in the User's Connection Agreement or other agreements.
- DCC9.4.3 The DSO shall provide the User the information and signals necessary for the interface co-ordination and operation of the User's protection, in accordance with the relevant provisions of the Connection Agreement, other agreements and DCC9.3.4.4.
- DCC9.4.4 Where it is feasible to do so DSO shall provide circuit breaker fail protection on Grid Connection Point circuit breakers installed in new 110kV stations.

DCC9.5 Power Quality

DCC9.5.1 Users shall ensure that their connection to the Distribution System does not result in the level of distortion or fluctuation of the supply Voltage on the Distribution System, at the Connection Point, exceeding that allocated to them following consultation with the DSO. Distortion and fluctuations limits are outlined in IEC/TR3 61000-3-6 (Harmonics) and IEC/Tr3 61000-3-7 (Voltage Fluctuation). Users shall operate their plant in a manner which will not cause the requirements contained in CENELEC Standard EN 50160 to be breached.

DCC9.6 Signals to be provided by the User

DCC9.6.1 Each User shall provide such signals and indications in relation to the User's Plant and Apparatus as are required by the DSO (acting reasonably) in accordance with the Connection Agreement.

DCC9.6.2 Signals and indications required to be provided by Users will include but shall not be limited to the following:

- a) LV switchgear positions to the status of each 110kV Connected Transformer through a set of two potential free auxiliary contacts (one contact open and one contact normally closed when the circuit breaker is open) for each circuit breaker;
- b) kV at transformer low Voltage terminals; and
- c) a minimum of four sets of normally open potential free auxiliary contacts in each transformer LV bay for fault indication.

d), e), f), g) and H) are applicable to Generators only

- d) MW and +/-MVAR at alternator terminals of each Generation Unit;
- e) kV at Generator Transformer LV terminals
- f) Generator Transformer tap position
- g) Measured or derive MW output on each fuel, from Generation Units that can continuously fire on more than one fuel simultaneously; and
- h) Where it is agreed between the DSO and the Generator that signals are not available on the HV terminals, +/-MW and +/-MVAR shall be provided at the 110kV Connector Transformer low Voltage terminals.
- i) Status of Governor Control System and any Load limiters.

j)_and k) are applicable to Demand Customers only:

- j) MW and +/- MVAR at the HV terminals of the 110kV step up Transformer.
- k) 110kV Connector Transformer tap position.

DCC9.6.3 Where signals or indications required to be provided by the User under DCC9.6.2 become unavailable or do not comply with applicable standards due to failure of the User's technical equipment or any other reason under the control of the User, the User shall, acting in accordance with Good Industry Practice, restore or correct the signals and/or indications as soon as possible.

DCC9.6.4 Signals to be provided to the User shall be presented in such form as is nominated by the DSO or TSO where appropriate.

DCC9.6.5 Where, the DSO, acting reasonably, determines that because of a modification to the Distribution System or otherwise to meet a Distribution System requirement, additional signals and/or indications in relation to the User's Plant and Apparatus are required, the DSO shall notify that requirement to the User. On receipt of such a notification the User shall promptly, and in accordance with Good Industry Practice, ensuring that such signals and/or indications are made available at the relevant marshalling rack.

DCC9.7 Power Supplies

DCC9.7.1 Each User shall provide:

- a) 400 V ac / 230V ac power supplies as required by the DSO for Distribution Station Facilities, the capacity and detail of which shall be specified by the DSO and provided for the User's Connection Agreement.
- b) A standby supply for all ac power supplies for Distribution Station facilities by a diesel generator, unless alternative means are agreed with the DSO, such agreement not to be unreasonably withheld. In the event of loss of mains, standby supplies shall be capable of being sustained for a minimum of 10 hours.

DCC9.8 Commissioning and Notification

DCC9.8.1 The DSO and the User shall, in accordance with the provisions set out in the Connection Agreement, meet to discuss Commissioning, including Commissioning Tests and Grid Code Tests. The User's obligations in relation to testing set out in this DCC9.8 are in addition to the requirements under the Connection Agreement.

DCC9.8.2 Users are required to carry out such tests (which are defined to be Grid Code Tests) as required in order to confirm that the User's Plant and Apparatus meets all requirements of the Grid Code which must be met prior to Operational Date. The DSO may, under the Connection Agreement, notify to the User such Grid Code Tests as it requires the User to carry out. The DSO may not necessarily test for DCC9.10.1.1 a), b), c), d) and e) but reserve the right to test to establish design and operational compliance. For the avoidance of doubt it is the responsibility of Users at all times to ensure their compliance with the Grid Code and testing successfully or otherwise shall not in any way diminish or reduce such responsibilities.

DCC9.8.3 Where commissioning is likely to involve a requirement for a Dispatch for Test purposes, the User shall, as soon as possible, notify the TSO of this requirement, including reasonable details as to the duration and type of Testing required. Users shall give the TSO reasonable advance notice (being not less than fifteen (15) Business Days) of the time of carrying out of the Commissioning Tests. The time and date of such commissioning shall be reconfirmed not less than three (3) Business Days before the time of carrying out such tests. In event that, having given such confirmation the User (acting reasonably) determines that such tests must be carried out prior to the time and date previously confirmed, then provided the User gives the TSO reasonable notice of the re-scheduled tests, he shall not be deemed to have failed to give the notice required. The User shall as soon as it becomes aware of the same, subsequently notify the TSO of any material changes in the requirement and details so notified.

DCC9.8.4 The information provided under DCC9.8.3 is for indicative purposes only, and the User shall subsequently make a formal request to the TSO for a Commissioning Test requiring a Dispatch in accordance with the following provisions of the DCC9.8, and shall not carry out such a Commissioning Test except as Dispatched in accordance with DCC9.8.

DCC9.8.5 Users shall make a request in writing to the TSO for every Commissioning Test requiring Dispatch, in accordance with DCC9.8.4. Such request to include the following information:

- DCC9.8.5.1 Details of the proposed Commissioning Test;
- DCC9.8.5.2 Dispatches, where necessary, required by the User for completion of the Commissioning Test, if any, including the duration of the Dispatch. Where the User may not know the entire Dispatches required for completion of the Test until part of the Test is completed then the User when proposing the Test shall:
- a) Divide the Commissioning Test in sections as appropriate;
 - b) Indicate and discuss which sections of the Commissioning Tests can be completed in stages and which cannot;
 - c) Indicate possible variations of the Commissioning Test for the sections which be completed in stages.
- Additionally the factors which influence the completion of the stages should be outlined to the TSO, (namely, if the procedure to be followed for a certain stage depends on the outcome of a previous stage);
- DCC9.8.5.3 the preferred time or times for the Commissioning Test;
- DCC9.8.5.4 the milestones for individual sections of Commissioning Test (if any) which can be completed separately, and/or do not require to be repeated if the commissioning Test is interrupted by the TSO after the completion of each section.
- DCC9.8.6 Generators will be subject to the Scheduling and Dispatch Codes a minimum of seven (7) days prior to the Operational Date and the Generation Unit will be available for Dispatch from the Operational Date.
- DCC9.8.7 Following the Connection Date but not later than the Operational Date Users shall verify (by giving the TSO such evidence as it may reasonably require including, without limitation, the results of the relevant Commissioning Test or Grid Code Test) technical data provided under the Planning Code and other technical data which the TSO reasonably requires to be verified to assess the compliance with the Grid Code or the Connection Agreement.
- DCC9.8.8 The values as confirmed or verified under DCC9.8 shall be included in the User's Registered Operating Characteristics and Registered Data.

DCC9.9 ADDITIONAL REQUIREMENTS FOR DISPATCHABLE DEMAND CUSTOMERS

DCC9.9.1 Signals, Communications and Control

- DCC9.9.1.1 The following signals and indications are required to be provided by Users to the TSO. They will include but shall not be limited to the following:
- a), b) and c) are applicable to Dispatchable Demand Customers who represent Demand Side Units which consists of an Individual Demand Site:
 - a) KW and +/-KVAR at alternator terminals of each Generator where applicable;
 - b) Measured or derived KW Output for each Generator at the HV terminals of the Transformer where applicable; and
 - c) Demand Reduction aggregated at the HV terminals of the Transformer.
 - d), e), f) and g) are applicable to Dispatchable Demand Customers who represent Demand Side Units which consists of an Aggregated Demand Site:

- d) The aggregated KW and +/-KVAR aggregated at alternator terminals of each Generator where applicable;
- e) When requested by the TSO, the KW and +/-KVAR of each Individual Demand Site at alternator terminals of each Generator where applicable;
- f) The aggregated measured or derived KW Output for each Generator aggregated at the HV terminals of the Transformer where applicable; and
- g) The Aggregated Demand Reduction aggregated at the HV terminals of the Transformer.

DCC9.9.1.2 Dispatchable Demand Customers shall provide the TSO the specification of the method of aggregation of SCADA from multiple sites. The minimum specifications shall be agreed with the TSO in advance.

DCC9.9.2 Responsible Operator

DCC9.9.2.1 For Dispatchable Demand Customers, the Control Facility shall be staffed by a Responsible Operator(s) who shall respond to communications from the TSO without undue delay (except where otherwise provided for by agreement between the Dispatchable Demand Customer or the and the TSO, such agreement not to be unreasonably withheld) and are of suitable experience and training and are authorised to perform functions on behalf of the Dispatchable Demand Customer as follows:

- (a) to accept and execute Dispatch Instructions;
- (b) to receive and acknowledge receipt of requests, for amongst other matters, operation outside the Declared values of Demand Reduction.

DCC9.9.2.2 A designated Responsible Operator shall be contactable by DSO or TSO at all times to discuss operational matters without undue delay and in any case within at most 1 hour. Following a request from DSO, the Responsible Operator shall be present at the Demand Side Unit Control Point without undue delay and in any case within two hours and shall be capable of taking any appropriate actions. The Responsible Operator shall be contactable 24 hours a day, 365 days a year. Specialist response shall be available on the next working day following a request from the DSO or TSO

DCC9.9.2.3 The Responsible Manager shall be authorised to perform the following functions on behalf of the Dispatchable Demand Customer:

- (a) to make estimates in accordance with Good Industry Practice as to the Demand Reduction;
- (b) to make Declarations of the Demand Reduction for each Demand Side Unit;
- (c) to communicate with respect to issues regarding Outages of each DSU.

The Dispatchable Demand Customer may, from time to time, notify a replacement contact location and personnel, which meets the foregoing requirements.

DCC9.9.3 Supervisory Control and Data Acquisition (SCADA)

DCC9.9.3.1 SCADA remote terminal equipment shall be required in the control room of the Transmission Station at the User Site for the transmission of signals and indications to and from the NCC. The signals and indications which must be provided by Users for transmission by SCADA equipment to the NCC are the signals and indications referred to under Connection Conditions together with such other information as the TSO may from time to time by notice to Users reasonably require.

DCC9.9.3.2 For Dispatchable Demand Customers, SCADA remote terminal equipment shall also be required at the Control Facility for the transmission of signals and indications to and from the NCC. The signals and indications which must be provided by Dispatchable Demand Customers for transmission by SCADA equipment to the NCC are the signals and indications referred to under Connection Conditions together with such other information as the TSO may from time to time, by notice to Dispatchable Demand Customers or and s, reasonably require.

DCC9.9.3.3 Interface cabinets shall be installed in the control room of the Transmission Station at the or in Dispatchable Demand Customer's Control Facility. Provision and maintenance of wiring and signalling from the Dispatchable Demand Customer's Plant and Apparatus to the Dispatchable Demand Customer's interface cabinet shall be the responsibility of the Dispatchable Demand Customer's. The TSO shall provide the cables to interconnect these interface cabinets.

DCC9.9.4 Monitoring, Testing and Investigation

DCC9.9.4.1 The response of the Dispatchable Demand Customer's Demand Side Units to Dispatch Instructions and compliance with their Availability Notice shall be monitored, tested and checked in accordance with OC8 and OC10 of the Grid Code.

DCC9.9.5 Scheduling and Dispatch of Demand Side Units

DCC9.9.5 .1 Scheduling and Declaration of Availability of the Demand Side Units shall be in accordance with SDC1 off the Grid Code.

DCC9.9.5 .2 The scheduling, dispatch and additional parameters required for Dispatching a Demand Side Units shall be in accordance with SDC1A of the Grid Code

DCC9.9.5.3 Dispatching of the Demand Side Units shall be in accordance with SDC2 off the Grid Code.

DCC9.9.6 Outage Planning

DCC9.9.6.1 The Dispatchable Demand Customers must adhere to the outage planning requirement as specified in OC2 of the Grid Code.

DCC9.9.7 Additional Connection Conditions

DCC9.9.7.1 Each Demand Side Unit shall, as a minimum, have the following capabilities:

- (a) Able to provide Demand Reduction between 0 MW and the Demand Reduction Capability
- (b) Max Ramp Up Capability not less than 1.5% of Demand Reduction Capability per minute when the Demand Side Unit is in Normal Dispatch Condition
- (c) Max Ramp Down Capability not less than 1.5% of Demand Reduction Capability per minute when the Demand Side Unit is in Normal Dispatch Condition
- (d) Minimum Down-Time Capability not greater than 30 minutes for Demand Side Units
- (e) Maximum Down- Time Capability not less than 2 hours for Demand Side Units

Each Demand Side Unit with on-site Generation, shall, as a minimum, have the following capabilities:

- (f) operate continuously at normal rated output at Frequencies in the range 49.5Hz to 50.5Hz;
- (g) remain synchronised to the Distribution System at Frequencies within the range 47.5Hz to 52.0Hz for a duration of 60 minutes;
- (h) remain synchronised to the Distribution System at Frequencies within the range 47.0Hz to 47.5Hz for a duration of 20 seconds required each time the Frequency is below 47.5Hz;
- (i) remain synchronised to the Distribution System during a rate of change of Frequency of values up to and including 0.5 Hz per second;

DCC9.9.7.2 Each Demand Side Unit will require Electronic Interface to receive Dispatch Instructions from the TSO.

Generator Requirements

DCC10 GENERATOR REQUIREMENTS

DCC10.1 INTRODUCTION

DCC10.1.1 Distribution Connection Code 10 (DCC10) is applicable to all existing or prospective Generators, including Customers with CHP, Customers with Auto-production and Generators using renewables or alternative sources of energy who are connected to the Distribution System. Customers with stand-by generators who are connected to the Distribution System must comply with clause DCC10.9.

DCC10.1.2 In addition to meeting the requirements of DCC10, Generators shall also comply with the requirements of the General Conditions, the Planning Code, the Connection Conditions and other relevant sections of the Distribution Code. Generators that are subject to central dispatch shall additionally have to comply with certain sections of the Grid Code.

DCC10.1.3 If existing generating plant does not comply with the standards set down in, or cannot comply (for technical or economic or other reasons) with, the requirements of this section, they shall seek a derogation from the provision from the Commission.

DCC10.1.4 The Generator shall initiate discussions at a sufficiently early stage in design to allow the DSO to examine the impact of the Generating Unit(s) on the Distribution System.

DCC10.1.5 The DSO may refuse permission for the connection of a Generating Unit at a point on the Distribution System or require revision to design or technical parameters of the generation unit, or impose certain restrictions in order to ensure that security and quality of supply standards as specified in DPC4 are maintained. In such instances, the DSO shall provide sufficient supporting information to justify the refusal or the required revisions.

DCC10.2 SPECIFIC RULES FOR GENERATORS

DCC10.2.1 The integrity of the Distribution System and the security and quality of supply to existing Users shall not fall below standard as a result of generators operating in parallel (synchronised) with the Distribution System. Conditions for operation shall guarantee the safety of:

- Members of general public
- Personnel
- Distribution Equipment

Supply quality to other customers shall not fall below standard as a result of the presence or operation of Generating Units.

DCC10.2.2 Generating Units connecting to the Distribution System and operating in parallel with, or which are capable of being operated in parallel with the Distribution System shall comply with "Conditions Governing Connection to the Distribution System: Connections at MV and 38kV and Generators at LV, MV and 38kV" (Item 7, Annex 1). This document sets out the conditions to which Generating Units operating in parallel to the Distribution System shall comply.

DCC10.2.3 Protection conditions and requirements set down in "Conditions Governing Connection to the Distribution System: Connections at MV and 38kV and Generators at LV, MV and 38kV" (Item 7, Annex 1) are to protect the Distribution System. The Generator is responsible for protection of his personnel and equipment and the efficient operation of his Generating Unit.

DCC10.2.4 Where a Generator Unit is to be installed in a premises the DSO shall be informed. The DSO shall have the right to inspect generating installations to ensure that the requirements are met. In some cases the DSO may require a demonstration by operation of the generator. Such demonstrations shall be by agreement with the User.

DCC10.3 PROVISION OF INFORMATION

DCC10.3.1 Information required from Generators

Generators shall provide to the DSO information on (a) the Generating Plant and (b) the proposed interface arrangements between the Generating Plant and the Distribution System. The information required by the DSO before entering into an agreement to connect any Generating Plant to the Distribution System is shown below and is detailed in Schedules 1 (a), 1 (b) and 1 (c) in the Distribution Data Registration Code (DDRC):-

(a) Generating Plant Data:

- (i) Terminal Volts(kV)
- (ii) Rated kVA
- (iii) Rated kW
- (iv) Maximum Active Power sent out (kW), Reactive Power requirements (kVAr)
- (v) Type of Generating Plant – synchronous, asynchronous, etc.
- (vii) Type of prime mover;
- (viii) Anticipated operating regime of generation e.g. continuous, intermittent, peak lopping;
- (ix) Fault Level Contribution – a calculation sheet showing the fault current available from the generators due to a metallic three-phase short circuit at the main incoming circuit breaker when all the generators are operating. Account should be taken of any large motors in the installation (ref: IEC 909).
- (x) Method of voltage control
- (xi) Generator transformer details, as applicable; and
- (xii) Requirements for Top-up Supplies and / or Standby Supplies

Details will also be required on the following parameters:

- (i) Inertia Constant MW secs/MVA (whole machine)
- (ii) Stator resistance
- (iii) Direct Axis Reactances Sub-transient
Transient
Synchronous
- (iv) Time Constants: Direct Axis Sub-transient
Transient
- (v) Zero Sequence Resistance
Reactance
- (vi) Negative Sequence Resistance
Reactance
- (vii) Generator Transformer Resistance
Reactance
MVA Rating
Tap Arrangement
Vector Group
Earthing

(b) Other Plant and Equipment Details:

A comprehensive schedule of installed new equipment including details of disturbing loads as per DCC4 is required.

(c) Interface Arrangements:

- (i) The means of synchronisation between the DSO and User;
- (ii) Details of arrangements for connecting with earth that part of the Generating Plant directly connected to the Distribution System;
- (iii) The means of connection and disconnection which are to be employed; and
- (iv) Precautions to be taken to ensure the continuance of safe conditions if any earthed neutral point of the Generators System operated at High Voltage become disconnected from earth.

DCC10.3.2 The details of information required will vary depending on the type and size of the Generating Unit or the point at which connection is to be made to the Distribution System. This information shall be provided by the Generator at the reasonable request of the DSO.

DCC10.3.3 The DSO will use the information provided to model the Generator Unit to determine a technically acceptable method of connection. If the DSO reasonably concludes that the nature of the proposed connection or changes to an existing connection requires more detailed analysis then further information than that specified in DCC10.3.1 may be required.

DCC10.3.4 Additional information may be required from generators larger than 2MW or connected at a voltage level above 20kV. This may include:

(a) Technical Data

- (i) Generating Plant information (impedance per unit on rating)

Type of prime mover
Rated MVA
MW
Type of excitation system

- (ii) Automatic Voltage Regulator (AVR)

A block diagram for the model of the AVR system including the data on the gains, forward and feedback gains, time constraints and voltage control limits.

- (iii) Speed Governor and Prime Mover Data

A block diagram for the model of the generating plant governor detailing the governor flyball, if applicable, and system control and turbine rating.

- (iv) Generator Excitation System

(b) Capacity and standby Requirements

- (i) Registered Capacity and minimum generation of each generating unit and power station in MW.
- (ii) Generating unit and power station auxiliary demand (active and reactive power) in MW and MVA_r, at registered capacity conditions.
- (iii) Generating Unit and power station auxiliary demand (active and reactive power) in MW and MVA_r, under minimum generation conditions.

DCC10.3.5 In normal circumstances the information specified above will enable the DSO to assess the connection requirements. Occasionally additional information may be required. In such circumstances, the information shall be made available by the Generator, at the reasonable request of the DSO.

DCC10.4 INFORMATION PROVIDED BY THE DSO

DCC10.4.1 The DSO shall prepare a statement as per DCC5.2. for Generators applying for connection to the Distribution System.

DCC10.4.2 Where Generator paralleling or power export is intended the following additional information shall be provided including:

- (a) Interface protection settings
- (b) Equipment, cabling, switchgear, metering requirements
- (c) Substation site and building requirements (dimensions, access, planning permission, earthing, lighting and heating)

DCC10.5 TECHNICAL REQUIREMENTS

DCC10.5.1 Generating Plant Performance Requirements

- (a) All centrally dispatched generators shall comply with the relevant sections of the Grid Code.
- (b) For Generators not subject to central dispatch the electrical parameters to be achieved at the Generating Unit terminals shall be specified by the DSO with the offer for connection.
- (c) Protection associated with Generating Plant shall be required to co-ordinate with the Distribution System protection regarding:
 - (i) clearance times for fault currents
 - (ii) co-ordination with auto recloser requirements
 - (iii) protection settings of the controlling circuit breaker

Protection settings shall not be changed without agreement from the DSO.

These protection requirements are additional to normal interface protection requirements of the User.

- (d) The emission limit for voltage fluctuations and flicker at the PCC caused by switching or continuous operation of wind / wave turbine installations is $P_{st} = 0.35$ and $P_{lt} = 0.35$ where:

P_{st} : Short Term Flicker Severity - an index of visual severity evaluated over a 10 minute period.

P_{lt} : Long Term Flicker Severity - an index of visual severity evaluated over a 2 hour period.

These values are consistent with IEC 1000-3-7.

- (e) For generators the Total Harmonic Voltage Distortion (THVD) limit is given in the table below:

| Voltage Level | Total Harmonic Voltage Distortion (%) |
|---------------|---------------------------------------|
| LV | 2.5 |
| MV | 2.0 |
| 38kV | 1.5 |

A schedule of individual harmonic distortion limits shall be provided by the DSO where appropriate.

- (e) The maximum voltage at the connection point with an generator is as per table 5.

Table 5 – maximum voltage at connection point with generators

| Nominal voltage | Highest voltage |
|------------------------|------------------------|
| 230V | 253V |
| 400V | 440V |
| 10kV | 11.3kV |
| 20kV | 22.5kV |
| 38kV | 43.8kV |
| 110kV | 120kV |

DCC10.6 ISLANDING

DCC10.6.1 It is conceivable that a part of the Distribution System, to which Generators are connected can, during emergency conditions, become detached from the rest of the System. The DSO may decide, dependent on local network conditions, if it is desirable for the Generators to continue to generate onto the islanded Distribution System.

DCC10.6.2 If not facilities exist for the subsequent resynchronisation with the rest of the Distribution System then the Generator shall under DSO instruction ensure that the Generating Plant is disconnected for resynchronisation.

DCC10.6.3 Under emergency conditions there is an expectation that some generation will continue to operate outside the statutory frequency limits. However, for Generators connected to the Distribution System it is likely that this could mean connection within an automatic low frequency load disconnection zone. Consequently, Generators should ensure that all Protection on Generating Plant should have settings to co-ordinate with those on the low frequency load disconnection equipment which will be detailed by the DSO on request.

DCC10.7 BLACK START CAPABILITY

DCC10.7.1 Generators shall notify the DSO if its Generating Plant has a restart capability without connection to an external power supply, unless the Generator has previously notified the TSO accordingly under the Grid Code.

DCC10.8 GENERATING PLANT COMMISSIONING TESTS

DCC10.8.1 Where the Generating Plant requires connection to the Distribution System in advance of the commissioning date, for the purposes of testing, the Generator shall comply with the requirements of the Connection Agreement. The Generator shall provide the DSO with a commissioning programme, approved by the DSO if reasonable in the circumstances, to allow Commissioning Tests to be co-ordinated.

DCC10.9 STANDBY GENERATORS

DCC10.9.1 Parallel operation with the Distribution System is generally not permitted for standby generators. Specific agreement of the DSO is required for parallel operation.

DCC10.9.2 Customers with standby generation shall ensure that any part of the installation supplied by the generating plant has first been disconnected from the Distribution System and remains disconnected while the generating plant is connected to the installation. Methods of changeover and interlocking shall meet these requirements. See National Rules for Electrical Installations Part 3.7 Supplementary Requirements for Low Voltage Synchronous Generator Installations (Item 15, Annex1).

DCC10.9.3 Low voltage Generating Units must comply with the relevant requirements published by the ETCI and the National Code of Practice for Customer Interface (Item4, Annex1). Medium and High voltage standby Generating Units are rare and requirements shall be provided by the DSO on application.

DCC10.10 ADDITIONAL REQUIREMENTS FOR 110kV CONNECTED GENERATORS > 2MW

DCC10.10.1.1 Each Generation Unit shall, as a minimum, have the following capabilities:

- (a) Operate continuously at normal rated output at the Distribution System Frequencies in the range of 49.5Hz to 50.5Hz;
- (b) Remain synchronised to the Distribution System at Distribution System Frequencies within the range of 47.5Hz and 52.0Hz for a duration of 60 minutes;
- (c) Remain synchronised to the Distribution System at Distribution System Frequencies within the range of 47.0Hz and 47.5Hz for a duration of 20 seconds required each time the Frequency is below 47.5Hz;
- (d) Remain synchronised to the Distribution System during a rate of change of the Distribution System Frequency of values up to and including 0.5Hz per second.;
- (e) Sustained operation at the specified Minimum Generation within the range 49.8 to 50.1 Hz;
- (f) Remain synchronised to the Distribution System at normal rated output at Distribution System Voltages within the ranges in DCC8.3.8.3.2 for step changes in the Distribution System Voltage of up to 10%.

- (g) Sustained operation in accordance with the Reactive Power capability as required by DCC10.10.2 at Distribution System Voltages within the ranges specified in DPC4.2.2, unless otherwise specified.
- (h) Remain synchronised during Voltage dips at the HV terminals of the Generator Transformer of 95% of nominal Voltage (5% retained) for a duration of 0.6 seconds;
- (i) Remain synchronised to the Distribution System during a negative phase sequence load unbalance in accordance with IEC 600034-1.
- (j) Minimum Load Not greater than 50% of Registered Capacity for CCGTs and not greater than 35% of Registered Capacity for all other Generation Units.
- (l) Ramp up capability Not less than 1.5% of Registered Capacity per minute when the Unit is in the Normal Dispatch Condition.
- (m) Ramp down capability Not less than 1.5% of Registered Capacity per minute when the Unit is in Normal Dispatch Condition.
- (n) Minimum up-time Not greater than 4 hours for Thermal Units
- (o) Minimum down-time Not greater than 4 hours for Thermal Units
- (p) Forbidden Zones Within the range between normal minimum load plus 5% and Registered Capacity less 10%, not more than 2 specified zones each not greater than 10% of Registered Capacity.
- (q) Block Loading Not greater than 10% of Registered Capacity
- (r) Time off-load before going into longer standby conditions Remain in a hot condition for at least 12 hours and remain in a warm condition for at least 60 hours.
- (s) Time to Synchronise (from instruction) Hot: not greater than 3 hours
Warm: not greater than 8 hours
Cold: not greater than 12 hours
- (t) (i) Time from Synchronising to Minimum Load Hot: Not greater than 40 Minutes
Warm: not greater than 90 minutes
Cold: not greater than 180 minutes
- (ii) Time to Deload from Minimum Load to De-Synchronising Hot: not greater than 40 minutes
Warm: not greater than 90 minutes
Cold: not greater than 180minutes

- (u) Operating Reserve
 - (i) POR not less than 5% of Registered Capacity
To be provided, at a minimum, at MW outputs in the range from 50% to 95% Registered Capacity, with provision in the range of 95% to 100% Registered Capacity to be not less than that indicated by a straight line with unity decay from 5% of Registered Capacity at 95% output to 0 at 100% output.
 - (ii) SOR not less than 5% Registered Capacity
To be provided, at a minimum, at MW outputs in the range from 50% to 95% Registered Capacity, with provision in the range of 95% to 100% Registered Capacity to not less than that indicated by a straight line with unity decay from 5% of Registered Capacity at 95% output to 0 at 100% output.
 - (iii) TOR1
To be provided, at a minimum, at MW outputs in the range from 50% to 92% Registered Capacity, with provision in the range of 92% to 100% Registered Capacity to be not less than that indicated by a straight line with unity decay from 8% of Registered Capacity at 92% output to 0 at 100%
 - (iv) TOR2
To be provided, at a minimum, at MW outputs in the range from 50% to 90% Registered Capacity, with provision in the range of 90% to 100% Registered Capacity to be not less than that indicated by a straight line with unity decay from 10% of Registered Capacity at 90% to 0 at 100%
- (v) The DSO may request Generation Units of Registered Capacity greater than or equal to 60MW to have the capacity to operate under SFRS at all loads between SFRS Minimum Load and SFRS Maximum Load.

DCC10.10.1.3 Notwithstanding DCC10.10.1.1 combustion turbine, hydro or other technology based Generation Units shall as appropriate, register and perform to operating characteristics giving maximum flexibility of operation, consistent with their type and model of generation plant, in accordance with Good Industry Practice. Where appropriate, operating characteristics and in particular start times, should be registered separately for normal (planned) starts, and for starts required under conditions of system stress, such as following the loss of a Generation Unit. The Generator will maintain operational procedures and practices, which ensures that there are no unnecessary delays in responding to Dispatch instructions in accordance with the technical capabilities of the Generation Plant.

DCC10.10.1.4 Where the TSO approaches a Generator, the Generator will co-operate with the TSO in the development of procedures and facilities to improve the response of each Generation Unit during conditions of system stress, including for example, automatic start-up of fast-start Generation Units following a loss of a Generation Unit(s) or in advance of an anticipated loss of a Generation Unit(s). This shall be subject to agreement of the Generator that the procedures are consistent with secure operation of the Generator's Plant, such agreement not to be reasonably withheld.

DCC10.10.1.5 Where start-up time of Generation Units exceeds 30 minutes, they shall be designed to have the capability, where supply from the Distribution System is lost, to reduce output to match house load and sustain operation (i.e. tripping to Auxiliaries).

DCC10.10.1.6 Control Synchronising shall be provided by Generators at Circuit Breakers identified by the DSO, which, depending on the Plant configuration may include:

- a) The Generation Unit circuit breaker
- b) The Generator Transformer LV and HV circuit breakers

The DSO will provide to the Generator signals from the DSO operated Plant and Apparatus as are required to facilitate synchronising on the Generator Transformer HV circuit breaker, in accordance with the relevant provisions of the Connection Agreement.

DCC10.10.1.7 The Synchronising facilities in DCC10.10.1.6 shall facilitate Synchronising under the following conditions:

- a) Distribution System Frequency within the limits 48.0 to 52.0 Hz
- b) Distribution System Voltage within the limits 99kV to 123kV notwithstanding DCC10.10.2.

DCC10.10.1.8 Each Generation Unit shall be designed, where practicable, to mitigate the risk of common failure with other Generation Units. In particular each Generation Unit shall be designed so that it can operate with its essential auxiliaries supplied through the unit transformer which shall be connected between the Generation Unit circuit breaker and the Generator Transformer LV terminals, or from another secure source as agreed with the DSO. Auxiliary suppliers may, provided that they are in accordance with Good Industry Practice, be taken from an alternative source during commissioning, testing, start-up or emergencies.

In the case of a CCGT installation, this applies to the Combustion Turbines Units only.

DCC10.10.2 Reactive Power capability

DCC10.10.2.1 Each Generation Unit shall have the following Reactive Power capability as measured at their alternator terminal :

| Voltage Range | Connected at: | At 100% Registered Capacity | At 35% of Registered Capacity |
|--|---------------|--|---|
| $99\text{kV} \leq V \leq 123\text{kV}$ | 110kV | 0.93 power factor leading to 0.85 power factor lagging | 0.7 power factor leading to 0.4 power factor lagging |
| $85\text{kV} \leq V \leq 99\text{kV}$ | | Unity power factor to 0.85 power factor lagging | 0.7 power factor leading to 0.4 power factory lagging |

DCC10.10.2.2 At between Registered Capacity and 35% Registered Capacity, Mvar capability to be not less than indicated by a straight line drawn between the two points from the above, on a plot of Mvar capability against MW output.

DCC10.10.2.3 At below 35% Registered Capacity, Mvar capability to be not less than that at 35% Registered Capacity.

DCC10.10.2.4 The Generator Transformer shall be designed such that the Reactive Power capability is possible over the full range of Distribution System Voltages (Specified in DCC10.10.2.1)

DCC10.10.2.5 The DSO and the Generator will liaise on matters related to DCC10.10.2 at the design stage.

DCC10.10.3 Each Generation Unit must be fitted with a fast acting proportional turbine speed governor and unit load controller or equivalent control device to provide Frequency Response under normal operating conditions in accordance with OC4 of the Grid Code.

DCC10.10.4 All Generation Units shall be capable of contributing to control of the Distribution System Voltage by continuous modulation of Generator Voltage by means of a suitable continuous acting Automatic Voltage Regulation (AVR) which shall comply with BS4999 part 140 or equivalent European Standards and the characteristics of which have been accepted by the DSO prior to the Connection Date, such acceptance not to be unreasonably withheld.

DCC10.10.5 Each Generator Transformer shall have on-load tap-changing (OLTC). The tap step shall not alter the Voltage ratio at the HV terminals by more than:

- a) 2.5% on the 110kV system

DCC10.10.6 Protection

DCC10.10.5.1 Generators will provide:

- a) Differential protection on the Generator Transformer. The connections between the Grid Connection Point circuit breaker and the HV terminals of the Generator Transformer shall be included in the protected zone of this differential protection.
- b) Backup protection (to the Distribution System) on Generation Units. The DSO acting reasonably shall require one or more of the following to be installed: generator overcurrent protection, voltage controlled generator, overcurrent protection or generator distance protection;
- c) Under frequency protection; and
- d) Generation Unit loss of excitation protection.

DCC10.10.5.2 The DSO may require an individual Generator, or group of Generators, to install additional protection and/or control schemes, where the DSO can reasonably show that it is prudent or necessary to do so. These schemes may include but are not limited to:

- a) Generation Unit over/under-voltage protection
- b) Generation Unit over-frequency protection
- c) Generation Unit transformer neutral displacement voltage detection.
- d) Loss of mains protection (rate of change of frequency or vector shift)
- e) Generation Unit pole slip protection
- f) Power System stabiliser

DCC10.10.5.3 Distance protection shall be provided by the DSO at the Connection Point circuit breaker of the Generator Transformer.

DCC11 Additional Requirements for Wind Generation

DCC11.1.1 OBJECTIVE

The primary objective of DCC11 is to establish the technical rules to which Wind Farm Power Stations must comply in order to ensure that the DSO and the TSO can operate the Distribution System and Transmission System reliably, maximising wind penetration on both systems.

DCC11.1.2 SCOPE

DCC11 applies wholly or in part to the following Users:

- (a) Wind Farm Power Stations with Registered Capacity of 5 MW or more; and
- (b) "Wind Farm Power Stations with Registered Capacity less than 5 MW due to be developed on a Contiguous Wind Farm Site where the development of the Wind Farm Power Station results in the total Registered Capacity of Wind Farm Power Stations on the Contiguous Wind Farm Site exceeding or remaining above 5 MW unless the DSO agrees that the proposed Wind Farm Power Station is unrelated and independent of the Wind Farm Power Stations already present in the Contiguous Wind Farm Site;
- (c) DCC11.5 shall apply to Wind Farm Power Stations with Registered Capacity of 2 MW or more.

DCC11.1.4 APPLICABILITY

For the avoidance of doubt, where there is a conflict between the provisions of DCC11 and any other part of the Distribution Code this section (DCC11) shall take precedence.

An applicability matrix, which details the extent of application of DCC11 to various categories of Wind Farm Power Station, is given in Table 5. For the purposes of this section, five categories of Wind Farm Power Station connection types are identified for reference. These are defined as follows:

Connection Type A

Wind Farm Power Stations are classed as being Connection Type A when connected, at 110kV to a DSO operated 110kV busbar.

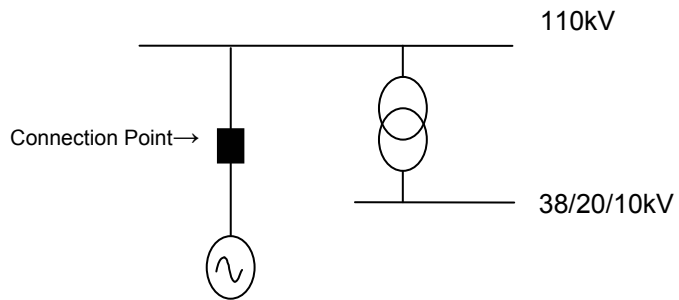
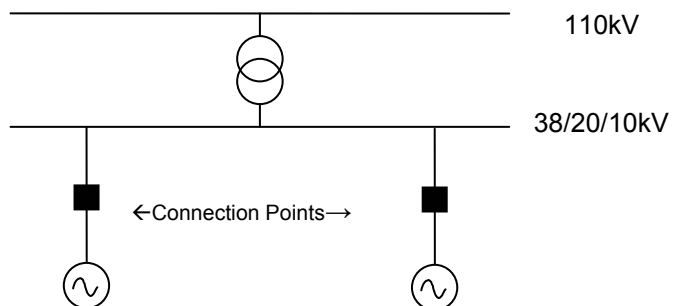

Figure 4

Connection Type B

Wind Farm Power Stations are classed as being Connection Type B when connected at a Distribution System Voltage (≤ 38 kV) to a dedicated Wind Farm Power Station(s) transmission station. There are no load customers connected to the DSO operated 38/20/10 kV busbar.



Connection Type C

Wind Farm Power Stations are classed as being Connection Type C when connected to the Distribution System, via a dedicated feeder, into an existing 110kV station.

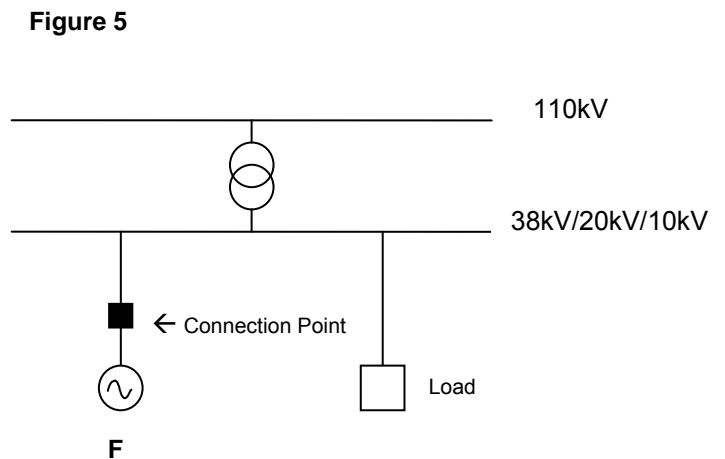

Figure 6

Connection Type D

Wind Farm Power Stations are classed as being Connection Type D when connected to the Distribution System via a dedicated 38kV, 20kV or 10kV feeder into an existing 38kV distribution station.

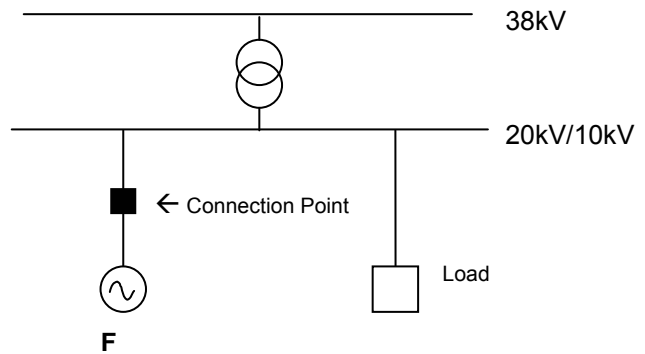

Figure 7

Connection Type E

Wind Farm Power Stations are classed as being Connection Type E when connected to an existing distribution line with load.

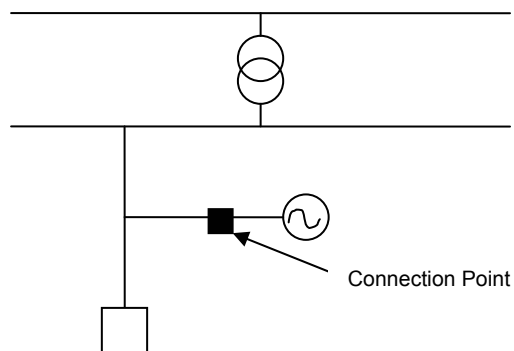

Figure 8

Table 5 indicates how the various requirements outlined in DCC11, will apply to the connection types described above. In addition, Centrally Dispatched windfarms must comply with DCC10.5.1a. For avoidance of doubt, the MW shown in Table 5 refer to:

1. The MW of generation of an individual windfarm; or
2. The sum of the MW of generation of contiguous windfarms that are not deemed to be independent.

Table 5: Applicability Matrix

| | Section | TYPE A | TYPE B | TYPE C | TYPE D | TYPE E |
|--|--------------------------|--------|---|-----------------------------|-----------------------------|-----------------------------|
| Fault Ride-Through | DCC 11.2 | All | ≥ 5 MW | ≥ 5 MW | ≥ 5 MW | ≥ 5 MW |
| FREQUENCY | | | | | | |
| Tolerance over Frequency Range | DCC11.3.1 | All | All | All | All | All |
| Participation in High Frequency Control | DCC11.3.2.3 | All | ≥5 MW | ≥5 MW | ≥5 MW | ≥5 MW |
| Participation in Low Frequency Control | DCC11.3.2.3 | All | ≥5 MW | ≥5 MW | ≥5 MW | ≥5 MW |
| Adherence to Maximum Ramp Rates | DCC11.3.4 | All | ≥5 MW | ≥5 MW | ≥5 MW | ≥5 MW |
| Active-Power Control Participation | DCC11.3.2.2 | All | ≥5 MW | ≥5 MW | ≥5 MW | ≥5 MW |
| VOLTAGE | | | | | | |
| Voltage Regulation¹ | DCC11.4.1 | N/A | ≥5 MW | N/A | N/A | N/A |
| Voltage Regulation | DCC11.4.2 DCC11.5.2.3 | All | N/A | N/A | N/A | N/A |
| Power Factor | DCC11.4.3 | N/A | < 5MW | All | All | All |
| Reactive Power Range | DCC11.4.5 | All | ≥5 MW | N/A | N/A | N/A |
| SIGNALS/COMMUNICATIONS/CONTROL | | | | | | |
| Signal List 1 | DCC11.5.1.1 | All | ≥5 MW | ≥5 MW | N/A | N/A |
| Signal List 2 | DCC11.5.1.2 | N/A | N/A | N/A | ≥5 MW | ≥5 MW |
| Signal List 3: Availability | DCC11.5.1.3 | All | ≥5 MW | ≥5 MW | ≥5 MW | ≥5 MW |
| Signal List 4: Active-Power Control | DCC11.5.1.4 | All | ≥5 MW | ≥5 MW | ≥5 MW | ≥5 MW |
| Signal List 5: Frequency Control | DCC11.5.1.5 | All | ≥5 MW | ≥5 MW | ≥5 MW | ≥5 MW |
| Signal List 6: Meteorological Data | DCC11.5.1.6 | All | ≥10 MW | ≥10 MW | ≥10 MW | ≥10 MW |
| Signal List 7: DSO SCADA Signals | DCC11.5.1.7 | N/A | ≥2 MW <5 MW ² | ≥2 MW <5 MW ² | ≥2 MW <5 MW ² | ≥2 MW <5 MW ² |
| Ability to Accept Control Signal-Active-Power Control | DCC11.5.2.1 | All | ≥5 MW | ≥5 MW | ≥5 MW | ≥5 MW |
| Ability to Accept Control Signal-Frequency Control Curve Mode Change | DCC11.5.2.2 | All | ≥5 MW | ≥5 MW | ≥5 MW | ≥5 MW |
| Ability to Accept Control Signal-Voltage Control | DCC11.4.1 DCC11.4.2 | All | ≥5 MW | N/A | N/A | N/A |
| Installation of recloser at the Windfarm Power Station site for network protection | DCC11.5.2.8 | N/A | All medium voltage connections | | | |
| Ability to receive Network Operator Initiated Shutdown command from DSO via DSO RTU or ability to be remotely disconnected by DSO via device located at or near Wind Farm Power Station³ | DCC11.5.2.4 | N/A | Medium voltage connections ≥ 2MW and <5MW | | | |

¹ Participation in Voltage Regulation- Mechanism to be agreed between TSO/DSO

² In certain circumstances, depending on future changes to the network connection, topology, the amount of embedded generation on the particular network and system reasons, generators with an MEC <2MVA may be required to provide telecommunication infrastructure for SCADA.

| | Section | TYPE A | TYPE B | TYPE C | TYPE D | TYPE E |
|---|---------------|--------------|--------------------------------------|--------------|--------------|--------------|
| | | | | | | |
| Ability to receive Network Operator initiated Shutdown command from DSO via DSO RTU | DCC11.5.2.4 | N/A | 38kV connections \geq 2MW and <5MW | | | |
| Ability to receive Network Operator Initiated Shutdown command from DSO or TSO via TSO RTU | DCC11.5.2.4 | All | \geq 5 MW | | | |
| Responsible Operator | DCC11.5.2.6.1 | N/A | All | All | All | All |
| Responsible Operator | DCC11.5.2.6.2 | All | N/A | N/A | N/A | N/A |
| Declarations | DCC11.5.4 | \geq 30 MW | \geq 30 MW | \geq 30 MW | \geq 30 MW | \geq 30 MW |
| Wind Power Forecasts | DCC11.5.3 | \geq 30 MW | \geq 30 MW | \geq 30 MW | \geq 30 MW | \geq 30 MW |

³ For medium voltage connections \geq 2MW and <5MW, provided that adequate media coverage exists, remote operation of the recloser deployed to satisfy DCC10.5.2.8 may also be used to implement the requirements of DCC10.5.2.4 and DCC10.5.1.7.

DCC11.2 FAULT RIDE THROUGH REQUIREMENTS

DCC11.2.1 Types B, C, D and E Wind Farm Power Stations shall remain connected to the Distribution System for Voltage dips on any or all phases, where the Distribution System Phase Voltage measured at the Connection Point remains above the heavy black line in Figure 9.

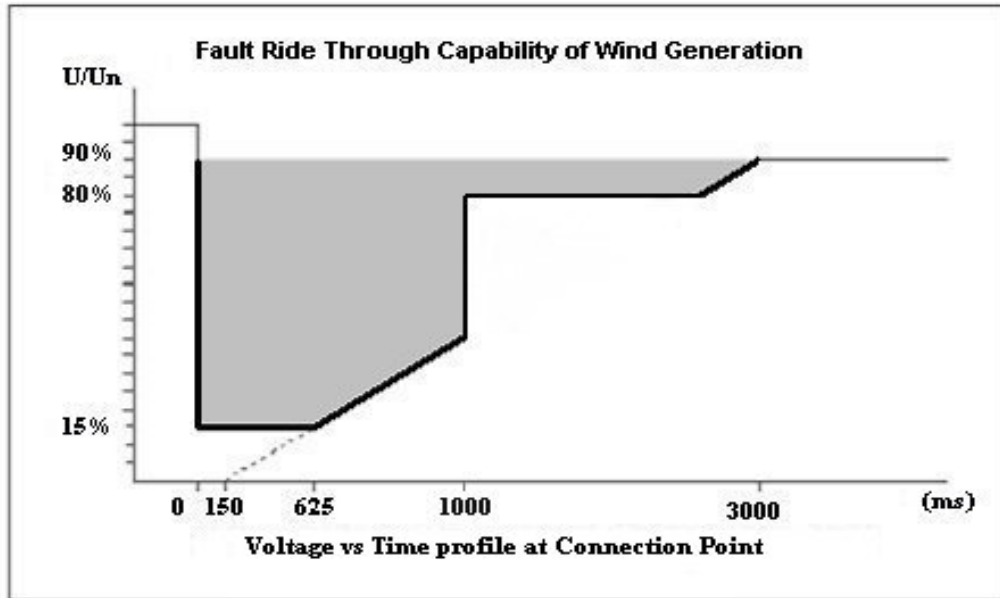

Figure 9: Fault Ride-Through Capability for Types B, C, D and E Wind Farm Power Stations connected to the Distribution System

DCC11.2.2 Type A Wind Farm Power Stations shall remain connected to the Distribution System for Voltage dips on any or all phases, where the Distribution System Phase Voltage measured at the Connection Point remains above the heavy black line in Figure 10.

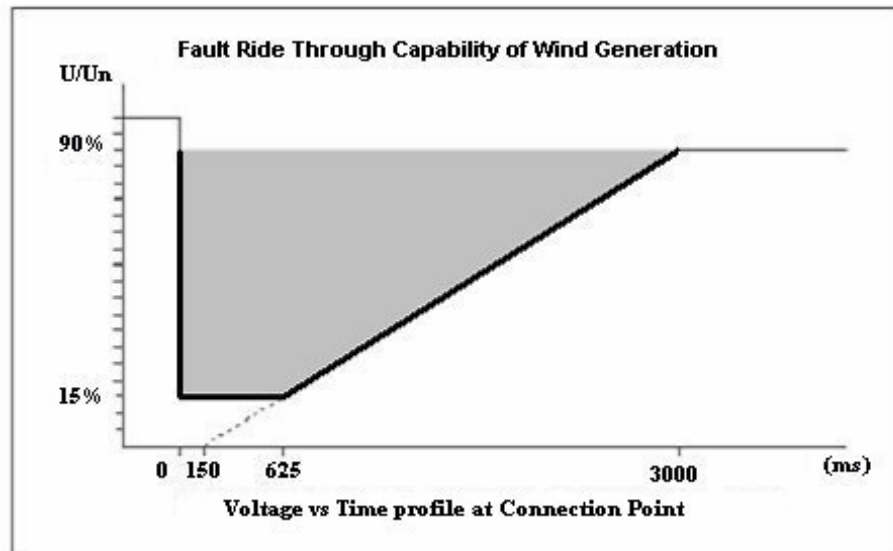

Figure 10: Fault Ride-Through Capability for Type A Wind Farm Power Stations connected to the Distribution System.

DCC11.2.3 In addition to remaining connected to the Distribution System, the Wind Farm Power Station shall have the technical capability to provide the following functions:

- a) During the Voltage dip the Wind Farm Power Station shall provide Active Power in proportion to retained Voltage and maximise reactive current to the Distribution System without exceeding WTG limits. The maximisation of reactive current shall continue for at least 600ms or until the Distribution System Voltage recovers to within the normal operational range of the Distribution System, whichever is the sooner.
- b) The Wind Farm Power Station shall provide at least 90 % of its maximum Available Active Power as quickly as the technology allows and in any event within 1 second of the Distribution System Voltage recovering to the normal operating range

DCC11.3 FREQUENCY REQUIREMENTS

DCC11.3.1 FREQUENCY RANGES

Wind Farm Power Stations shall have the capability to:

- a) operate continuously at normal rated output at Frequencies in the range 49.5 Hz to 50.5 Hz
- b) remain connected to the Distribution System at Frequencies within the range 47.5 Hz to 52 Hz for a duration of 60 minutes. Note that setting of the G10 Generator Interface Protection will determine actual operation in this range (see Table 6).
- c) remain connected to the Distribution System at Frequencies within the range 47.0 Hz to 47.5 Hz for a duration of 20 seconds required each time the Frequency is below 47.5 Hz.
- d) remain connected to the Distribution System during rate of change of Frequency of values up to and including 0.5 Hz per second.

No additional WTG shall be started while the Frequency is above 50.2 Hz.

| Protection Function | Frequency Setting | Time Setting |
|-----------------------------|-------------------|--------------|
| Over Frequency | 50.8Hz | 0.5s |
| Under Frequency | 47Hz | 0.5s |
| Rate-of-change-of-Frequency | 0.55Hz/s | < 0.5s |
| Under-voltage | 80% of nominal | 1s |

Table 6: Currently applicable Generator Interface Protection settings

DCC11.3.2 ACTIVE-POWER MANAGEMENT

DCC11.3.2.1 A Wind Farm Control System shall be installed by the Wind Farm Power Station to allow for the provision of Active-Power Control and Frequency Response from the Wind Farm Power Station. The Wind Farm Control System and Frequency Response System shall provide the functionality as specified in this section DCC11.3.2.

DCC11.3.2.2 Active-Power Control

The Wind Farm Control System shall be capable of operating each WTG at a reduced level if the Wind Farm Power Station's Active Power has been restricted by the TSO for system security reasons. The Wind Farm Control System shall be capable of receiving an on-line Active-Power Control Set-point sent by the TSO and shall commence implementation of the set-point within 10 seconds of receipt of the signal from the TSO. The rate of change of output to achieve the Active-Power Control Set-point should be no less than the maximum ramp rate settings of the Wind Farm Control System, as advised by the TSO, as per DCC11.3.4.

DCC11.3.2.3 Frequency Response

The Frequency Response System shall have the capabilities as displayed in the Power-Frequency Response Curve in Figure 11.

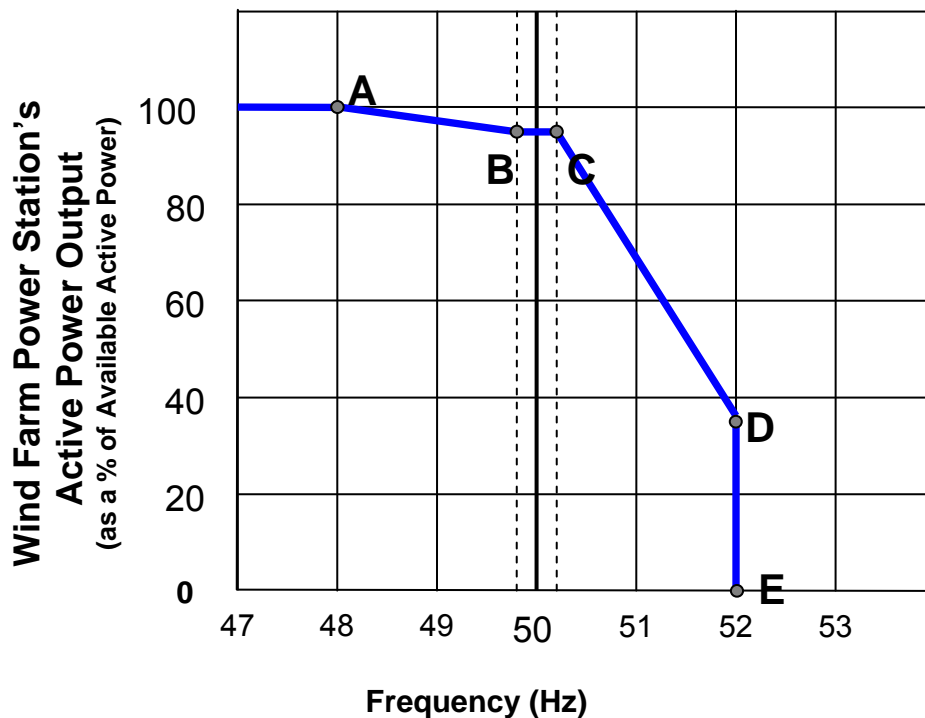

Figure 11 - Power-Frequency Control Curve

- DCC11.3.2.3.1 Under normal Frequency ranges, the Wind Farm Power Station shall operate with an Active Power output as set by the line 'B' - 'C'. If the Frequency falls below point 'B', then the Frequency Response System shall act to ramp up the Wind Farm Power Station's Active Power output in accordance with the Frequency/Active Power characteristic defined by the line 'B'-'A'.
- DCC11.3.2.3.2 Where the Frequency is below the normal range and is recovering back towards the normal range, the Frequency Response System shall act to ramp down the Wind Farm Power Station's Active Power output in accordance with the Frequency/Active Power characteristic defined by the line 'A'-'B'.
- DCC11.3.2.3.3 A Frequency dead-band shall be applied between the Frequencies corresponding to points 'B' and 'C', where no change in Wind Farm Power Station Active Power output shall be required.
- DCC11.3.2.3.4 Once the Frequency rises to a level above point 'C', the Frequency Response System shall act to ramp down the Wind Farm Power Station's Active Power output in accordance with the Frequency/Active Power characteristic defined by the line 'C'-'D'-'E'. At Frequencies greater than or equal to 'D'-'E', there shall be no Active Power output from the Wind Farm Power Station.

DCC11.3.2.3.5 Points 'A', 'B', 'C', 'D' and 'E' shall depend on a combination of the Frequency, Active Power and Active-Power Control Set-point settings,. These settings may be different for each Wind Farm Power Station depending on system conditions and Wind Farm Power Station location. These settings are defined in Table 6.

| Point | Frequency (Hz) | Wind Farm Power Station Active Power Output (% of Available Active Power) |
|-------|----------------|--|
| A | F_A | P_A |
| B | F_B | Minimum of : P_B or Active-Power Control Set-point (converted to a % of Available Active Power) |
| C | F_C | Minimum of: P_C or Active-Power Control Set-point (converted to a % of Available Active Power) |
| D | F_D | Minimum of: P_D or Active-Power Control Set-point (converted to a % of Available Active Power) |
| E | F_E | $P_E = 0 \%$ |

Table 6: Frequency and % Available Active Power Settings for the Points A, B, C, D and E illustrated in Figure 9

Two settings for each of $F_A, F_B, F_C, F_D, F_E, P_A, P_B, P_C, P_D$ and P_E shall be specified by the TSO at least 120 business days prior to the Wind Farm Power Station's scheduled Operational Date. The Wind Farm Power Station shall be responsible for implementing the appropriate settings during Commissioning.

Alterations to the Active-Power Control Set-point may be requested in real-time by the TSO and the implementation of the set-point shall commence within 10 seconds of receipt of the signal from the TSO. The rate of change of output to achieve the active-power Control Set-Point should be no less than the maximum ramp rate settings of the Wind Farm Control System, as advised by the TSO, as per DCC11.3.4.

DCC11.3.2.3.6 The table below, Table 7, shows the Frequency and Active Power ranges for $F_A, F_B, F_C, F_D, F_E, P_A, P_B, P_C, P_D$ and P_E

| | Frequency (Hz) | | Available Active Power (%) | |
|-------|----------------|-------|----------------------------|-------------------|
| | | | MEC ≥ 10 MW | 5 MW ≤ MEC <10 MW |
| F_A | 47.0-51.0 | P_A | 50-100 | 100 |
| F_B | 49.5-51.0 | P_B | 50-100 | 100 |
| F_C | | P_C | | |
| F_D | 50.5-52.0 | P_D | 20-100 | 20-100 |
| F_E | | P_E | 0 | 0 |

Table 7: Frequency & Active Power ranges appropriate to Figure 9.

For the Frequency values in Table 7 above, $F_A \leq F_B \leq F_C \leq F_D = F_E$.

- DCC11.3.2.3.7 Alterations to the Wind Farm Power Station's Active Power output, triggered by Frequency changes, shall be achieved by proportionately altering the Active Power output of all available WTG as opposed to switching individual WTG on or off, insofar as possible.
- DCC11.3.2.3.8 No time delay other than those necessarily inherent in the design of the Frequency Response System shall be introduced. The response rate of each available online WTG shall be a minimum of 1% of WTG rated capacity per second (MW/second). The Frequency Response System shall continuously monitor the Frequency in order to continuously determine the Wind Farm Power Station's appropriate Active Power output by taking account of the Wind Farm Power Station's Available Active Power or Controlled Active Power.
- DCC11.3.2.3.9 If the Frequency rises to a level above the line 'D'-'E', as defined by the Power-Frequency Response Curve in Figure 9, DSO recognises that WTG may disconnect. Any WTG which has disconnected shall be brought back on load as fast as technically feasible (provided the Frequency has fallen to below 50.2 Hz).

DCC11.3.3 PROCEDURE FOR SETTING AND CHANGING THE POWER-FREQUENCY RESPONSE CURVES

Two Power-Frequency Response Curves (Curve 1 and Curve 2) shall be specified by the TSO at least 120 business days prior to the Wind Farm Power Station's scheduled Operational Date. The Wind Farm Power Station shall be responsible for implementing the appropriate settings during Commissioning. The Frequency Response System shall be required to change between the two curves within one minute from receipt of the appropriate signal from the TSO. The TSO shall give the Wind Farm Power Station a minimum of 2 weeks if changes to any of the curve's parameters (i.e. F_A , F_B , F_C , F_D , F_E , P_A , P_B , P_C , P_D or P_E) are required. The Wind Farm Power Station shall formally confirm that any requested changes have been implemented within two weeks of receiving the TSO's formal request.

DCC11.3.4 RAMP RATES

- DCC11.3.4.1 The Wind Farm Control System shall be capable of controlling the ramp rate of its Active Power output with a maximum MW per minute ramp rate set by TSO. There shall be two maximum ramp rate settings. The first ramp rate setting shall apply to the MW ramp rate average over one (1) minute. The second ramp rate setting shall apply to the MW per minute ramp rate average over ten (10) minutes. These ramp rate settings shall be applicable for all ranges of operation including start up, normal operation and shut down. DSO acknowledges that falling wind speed or Frequency Response may cause either of the maximum ramp rate setting to be exceeded.
- DCC11.3.4.2 It shall be possible to vary each of these two maximum ramp rate settings independently over a wide range of between 1 and 30 MW per minute. The Wind Farm Control System shall have the capability to set the ramp rate in MW per minute averaged over both one and ten minutes.

DCC11.3.4.3 Procedure for setting and changing the Ramp Rate Control

The ramp rate settings shall be specified by the TSO at least 120 business days prior to the Wind Farm Power Station's scheduled Operational Date. The Wind Farm Power Station shall be responsible for implementing the appropriate settings during Commissioning. The ramp rate settings may need to be changed from time to time depending on system needs. The TSO shall formally give the Wind Farm Power Station a minimum of two weeks notice if a change is required. The Wind Farm Power Station shall formally confirm that any requested changes have been implemented within two weeks of receiving the TSO's formal request.

DCC11.4 VOLTAGE REQUIREMENTS

- DCC11.4.1 For DSO Type B connected Wind Farm Power Stations, a form of Voltage Regulation will be required.
- DCC11.4.2 For DSO Type A connected Wind Farm Power Stations, Voltage Regulation, as detailed in the following section will be required.
- DCC11.4.2.1 Wind Farm Power Stations shall have a continuously-variable and continuously-acting Voltage Regulation System with similar response characteristics to a conventional Automatic Voltage Regulator and shall perform generally as described in BS4999 part 140, or equivalent European Standards.
- DCC11.4.2.2 The Voltage Regulation System shall be capable of receiving a Voltage Regulation Set-point for the Voltage at the 110kV side of the Wind Farm Power Station's 110kV step-up Transformer (Point Z in Figure 11) or at the Connection Point, as appropriate. The appropriate location shall be specified by the DSO at least 120 business days prior to the Wind Farm Power Station's scheduled Operational Date. The Voltage Regulation System shall act to regulate the Voltage at this point by continuous modulation of the Wind Farm Power Station's Reactive Power output, within its Reactive Power range and without violating the Voltage Step Emissions limits as set out in the IEC standard 61000-3-7:1996 Assessment of Emission limits for fluctuating loads in MV and HV power systems. A change to the Voltage Regulation Set-point shall be implemented within 20 seconds of receipt of the appropriate signal from the TSO.
- DCC11.4.2.3 The slope setting of the Voltage Regulation System shall be capable of being set to any value between 1 % and 10 %. The setting shall be specified by the DSO at least 120 business days prior to the Wind Farm Power Station's scheduled Operational Date. The Wind Farm Power Station shall be responsible for implementing the appropriate settings during Commissioning. The slope setting may be varied from time to time depending on System needs. The DSO shall give the Wind Farm Power Station a minimum of two weeks notice if a change is required. The Wind Farm Power Station shall formally confirm that any requested changes have been implemented within two weeks of receiving the DSO's formal request.
- DCC11.4.2.4 The speed of response of the Voltage Regulation System shall be such that, following a step change in Voltage at the 110kV side of the Wind Farm Power Station's 110kV step-up Transformer or at the Connection Point, as appropriate, the Wind Farm Power Station shall achieve 90 % of its steady-state Reactive Power response within 1 second.
- DCC11.4.2.5 Figure 12 shows the relevant points appropriate to the Voltage Regulation System for a Wind Farm Power Station. X is the high-voltage (HV) side of the WTG transformer, Y is the lower voltage (LV) side of the 110kV step-up Transformer and Z is the high-voltage side of the 110kV step-up Transformer or Connection Point. The Wind Farm Power Station's Voltage Regulation System shall act to regulate the Voltage at point Z.

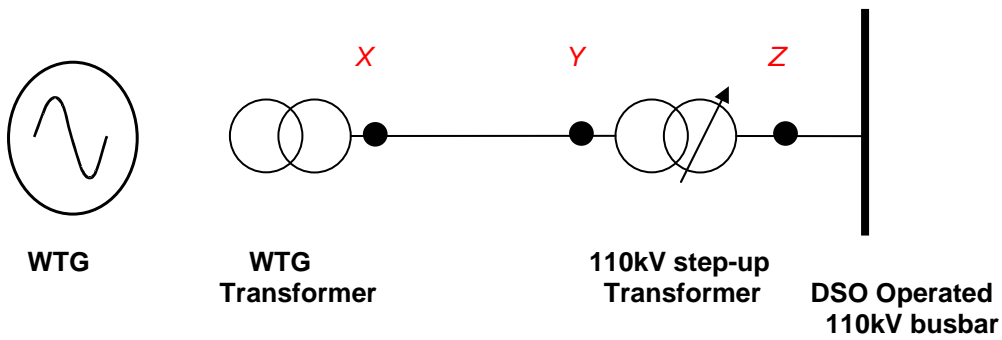

Figure 12 - Locations for Voltage Regulation set-point (Z) and the Reactive Power capability range (Y). The high-voltage side of the WTG transformer is (X).

DCC11.4.3 POWER FACTOR

Wind Farm Power Stations, with connection types B with a Registered Capacity of <5MW and connection types C, D or E, shall keep power factor between 0.92 and 0.95, as measured at the connection point, such that VARs are absorbed by the Wind Farm Power Stations from the Distribution System. This power factor range is illustrated in Figure 12a.

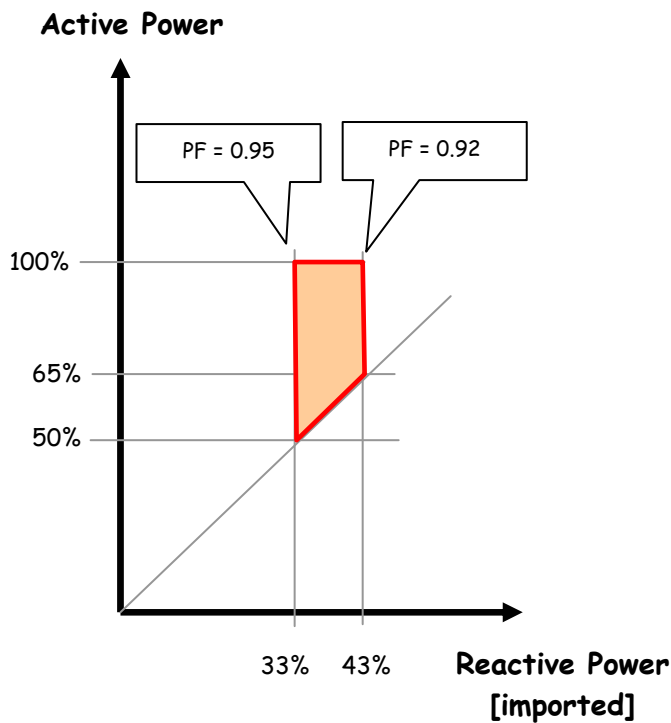

Figure 12a

DCC11.4.4 VOLTAGE RANGE

DSO Type A connected Wind Farm Power Stations shall remain continuously connected to the 110kV station at maximum Available Active Power or Controlled Active-Power output for normal and disturbed system conditions and for step changes in 110kV voltage of up to 10%. The following are the ranges that may arise during disturbances or following faults:

- 110kV system: 99kV to 123kV

DCC11.4.5 REACTIVE POWER CAPABILITY

DCC11.4.5.1 Wind Farm Power Stations, Type A connected, shall be capable of operating at any point within the Power Factor ranges illustrated below in Figure 13 as measured at the lower voltage side of the 110kV step-up Transformer (point Y in Figure 12), for any Voltage at the Connection Point within the range specified above.

DCC11.4.5.2 Wind Farm Power Stations, Type B with Registered Capacity $\geq 5\text{MW}$, shall be capable of operating at any point within the Power Factor ranges illustrated in Figure 13. The capability must be implemented at the Connection Point

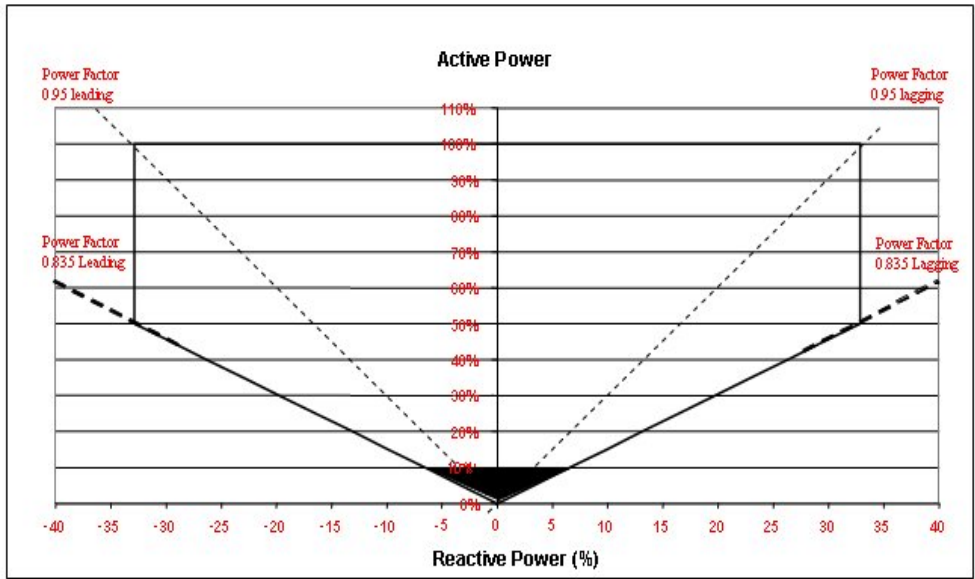

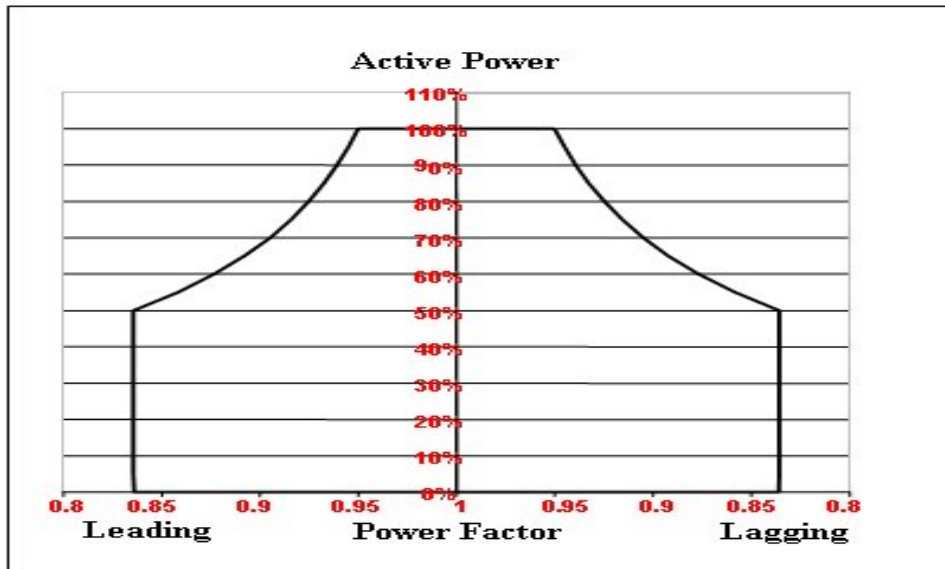

Figure 13 - Reactive Power Capability of Wind Farm Power Station

DCC11.4.5.3 For DSO Type A connected Wind Farm Power Stations where the Connection Point is remote from the 110kV step-up Transformer any supplementary Reactive Power compensation required to offset the Reactive Power demand of the HV line, or cable, between the Connection Point and the Wind Farm Power Station shall be identified during the Connection Offer process.

DCC 11.4.6 WIND FARM POWER STATION'S 110KV STEP-UP TRANSFORMER

DCC11.4.6.1 The 110kV step-up Transformer shall be designed such that the reactive power capability is possible over the full range of 110kV voltage specified in DCC 10.4.5

DCC11.4.6.2 Each 110kV step-up Transformer shall have on-load tap changing facilities. The tap step shall not alter the voltage ratio at the HV terminals by more than 2.5% or as agreed with the DSO.

DCC11.4.6.3 110kV step-up Transformers shall be connected either:

- In delta on the lower voltage side and in star (with the star point or neutral brought out) on the higher voltage side; or
- In star on both higher and lower voltage sides with a delta tertiary winding provided.

DCC11.4.6.4 Provision should be made for the earthing of the 110kV neutral of any transformer connected to the 110kV system by bringing out the neutral and ensuring that the insulation is such that the transformer can be operated unearthed.

DCC11.5 SIGNALS, COMMUNICATIONS & CONTROL

DCC11.5.1 Signals From The Wind Farm Power Station to TSO

Signals from the Wind Farm Power Station to the TSO shall be broken up into a number of logical groups. There are different requirements for Wind Farm Power Stations depending on the Wind Farm Power Station's MEC size. Refer to Table 5 for a summary of the signal requirements for different Wind Farm Power Station MEC.

The following groups shall apply:

- Signals List #1 - applies to Wind Farm Power Station Connection Types B and C.
- Signals List #2 - applies to Wind Farm Power Station Connection Types D and E

In addition, Wind Farm Power Stations shall be required to provide certain signals from Signals Lists 3, 4, 5, 6 and 7. These lists relate to:

- Signals List #3 Wind Farm Power Station Availability data;
- Signals List #4 Wind Farm Power Station Active-Power Control data;
- Signals List #5 Frequency Response System data;
- Signals List #6 Wind Farm Power Station Meteorological data;
- Signals List #7 DSO SCADA Signals.

DCC11.5.1.1 Signals List #1

The Wind Farm Power Station shall make the following signals available at the TSO Telecommunications Interface Cabinet located at the Wind Farm Power Station site:

- a) Active Power output (MW) at the Connection Point;
- b) Available Active Power (MW) at the Connection Point;
- c) Reactive Power output/demand (+/-MVar) at the Connection Point;
- d) On/off status indications for all Reactive Power devices exceeding 5 MVar⁴;
- e) Circuit-breaker position indication shall be required. These may include indications from HV as well as MV circuit-breakers on individual WTG circuits. Signals from individual WTG circuit-breakers shall not be required. The actual circuit-breaker signals required shall be specified by the TSO and subsequently advised by the DSO, at least 60 business days prior to the Wind Farm Power Station's scheduled Operational Date.
- f) On/off status of TSO Remote Control Enable switch, which disables the ability of the TSO to send commands to the Wind Farm Power Station.
- g) Voltage (kV) at the Connection Point
- h) For DSO Type A connected Wind Farm Power Stations the following additional signals are required:
 - 110kV step-up Transformer OLTC tap positions
 - Voltage in kV at the 110kV step-up Transformer low voltage terminals
 - Voltage Regulation Set-point (in kV)
 - A minimum of four sets of normally open potential free auxiliary contacts in each 110kV step-up Transformer lower voltage bay for fault indication

DCC11.5.1.2 Signals List #2

The Wind Farm Power Station shall make the following signals available at the TSO Telecommunications Interface Cabinet located at the Wind Farm Power Station site:

- a) Active Power output (MW) at the Connection Point;
- b) Available Active Power (MW) at the Connection Point;
- c) Reactive Power output/demand (+/-MVar) at the Connection Point;
- d) Voltage (kV) at the Connection Point

⁴ Typically the position indication from capacitor/SVC circuit breakers

- f) Circuit-breaker position indication shall be required. These may include indications from HV as well as MV circuit-breakers on individual WTG circuits. Signals from individual WTG circuit-breakers shall not be required. The actual circuit-breaker signals required shall be specified by the TSO and subsequently advised by the DSO at least 120 business days prior to the Wind Farm Power Station's scheduled Operational Date.

DCC11.5.1.3 Signals List #3

DCC11.5.1.3.1 The Wind Farm Power Stations, with an MEC in excess of 10 MW, shall make available the following signals at the TSO Telecommunications Interface Cabinet located at the Wind Farm Power Station site:

- a) Wind Farm Power Station Availability data (0-100% signal);
- b) Indication for percentage of the Wind Farm Power Station's WTG that are shutdown due to high-wind-speed conditions (0-100% signal);
- c) Indication for percentage of the Wind Farm Power Station's WTG that are shutdown due to low-wind-speed conditions (0-100% signal).

DCC11.5.1.3.2 For Wind Farm Power Stations where the WTG are widely dispersed over a large geographical area and rather different weather patterns are expected for different sections of the Wind Farm Power Station site, the above data set (specified in DCC11.5.1.3.1) shall be provided for a number of groups of WTG (e.g. 1 signal for each group of XX WTG within the Wind Farm Power Station site). It is expected that WTG within an individual group shall demonstrate a high degree of correlation in Active Power output at any given time. The actual signals required shall be specified by the TSO and subsequently advised by the DSO, at least 120 business days prior to the Wind Farm Power Station's scheduled Operational Date.

DCC11.5.1.4 Signals List #4

The Wind Farm Power Station shall make the following signals available at the TSO Telecommunications Interface Cabinet located at the Wind Farm Power Station site:

- a) Wind Farm Power Station Active-Power Control Set-point value (MW);
- b) Wind Farm Power Station Active-Power Control status indication (ON/OFF).

DCC11.5.1.5 Signals List #5

The Wind Farm Power Station shall make the following signals available at the TSO Telecommunications Interface Cabinet located at the Wind Farm Power Station site:

- a) Frequency Response System mode signal (i.e. Power-Frequency Response Curve 1 or 2);
- b) Frequency Response System status indication (ON/OFF).

DCC11.5.1.6 Signals List #6

DCC11.5.1.6.1 Wind Farm Power Stations, with an MEC in excess of 10 MW, shall make the following signals available at the TSO Telecommunications Interface Cabinet located at the Wind Farm Power Station site:

- | | |
|---|------------------|
| | [Units, Ranges] |
| a) Wind speed (at hub height) – measurand signal; | [m/s, 0-70] |
| b) Wind direction (at hub height) – measurand signal; | [deg, 0-360] |
| c) Air temperature- measurand signal; | [deg, -40-70] |
| d) Air pressure- measurand signal. | [mBar, 735,1060] |

DCC11.5.1.6.2 The meteorological data signals shall be provided by a dedicated Meteorological Mast located at the Wind Farm Power Station site or, where possible and preferable to do so, data from a means of the same or better accuracy. For Wind Farm Power Stations where the WTG are widely dispersed over a large geographical area and rather different weather patterns are expected for different sections of the Wind Farm Power Station, the meteorological data shall be provided from a number of individual Meteorological Masts, or where possible and preferable to do so, data from a source of the same or better reliability for groups of WTG (e.g. 1 set of meteorological data for each group of XX WTG within the Wind Farm Power Station site). It is expected that WTG within an individual group shall demonstrate a high degree of correlation in Active Power output at any given time. The actual signals required shall be specified by the TSO no more than 120 business days prior to the Wind Farm Power Station's scheduled Operational Date.

DCC11.5.1.7 **Signals List #7**
The following data signals and commands shall be provided by Wind Farm Power Stations:

- a) MW
- b) MVAR
- c) kV

DCC11.5.1.8 **Time Delays and data quality**

DCC11.5.1.8.1 A digital signal change from the Wind Farm Power Station shall be relayed to the TSO Telecommunications Interface Cabinet within 1 second of the associated change of state event. An analogue signal change shall be relayed within 5 seconds and with an error of 0.5% or less, with the exception of the Meteorological Data as required by DCC11.5.1.6.1, which shall be updated within 5 seconds and with an error of 2.5% or less.

DCC11.5.2 CONTROL SIGNALS FROM DSO/ TSO TO WIND FARM POWER STATIONS

The control signals described in DCC11.5.2 shall be sent from DSO or TSO to the Wind Farm Power Station. The Wind Farm Power Station shall be capable of receiving these signals and acting accordingly.

DCC11.5.2.1 **Active-Power Control**

An Active-Power Control Set-point signal shall be sent by TSO to the Wind Farm Control System. This set-point shall define the maximum Active Power output permitted from the Wind Farm Power Station. The Wind Farm Control System must be capable of receiving this signal and acting accordingly to achieve the desired change in Active Power output. This signal shall most likely be in the form of a single analogue value and a strobe pulse to enable. The Wind Farm Power Station is required to make it possible for the TSO to remotely enable/disable the Active-Power Control function in the Wind Farm Control System. The associated status indication is described in DCC11.5.1.4.

DCC11.5.2.2 **Frequency Response**

This signal shall be sent by TSO to the Wind Farm Power Station in the event that a change from Power Frequency Response Curve 1 to Power Frequency Response Curve 2, or vice versa, is required. The Wind Farm Power Station is required to make it possible for the TSO to remotely enable/disable the Frequency Response System. The associated status indication described in DCC11.5.1.5.

DCC11.5.2.3 **Voltage Regulation**

This signal shall allow the TSO to send a Voltage Regulation Set-point for Voltage Regulation purposes. This signal shall be in the form of a single analogue value and a strobe pulse to enable.

DCC11.5.2.4 Network Operator initiated shutdown

This signal shall facilitate the disconnection of the Wind Farm Power Station under blackstart conditions and/or if the Wind farm Power Station has to be disconnected for operational reasons.

For 38kV connections, it shall be possible for DSO to send a trip and / or inhibit signal⁵ to the circuit breaker at the Wind Farm Power Station Connection Point. The signal shall open the circuit breaker and switch off the auto-reclosing.

For MV connections:

- (a) It shall be possible for DSO to send a trip and / or inhibit signal⁶ to the circuit breaker at the Wind Farm Power Station Connection Point. The signal shall open the circuit breaker and switch off the auto-reclosing, or
- (b) A switching device capable of being remotely operated by DSO shall be installed at or near the Wind farm Power Station Connection Point.

DCC11.5.2.5 Time Delays and data quality

A digital output command from the TSO Telecommunications Interface Cabinet shall be relayed to the Wind Farm Power Station equipment within 1 second of the associated change of state event. A set-point output signal shall be relayed within 5 seconds and with an error of 0.5% or less.

DCC11.5.2.6 Responsible Operator

DCC11.5.2.6.1 A designated Responsible Operator shall be contactable by DSO or TSO at all times to discuss operational matters without undue delay and in any case within at most 1 hour. Following a request from DSO, the Responsible Operator shall be present at the Wind Farm Power Station's Connection Point without undue delay and in any case within two hours and shall be capable of taking any appropriate actions. The Responsible Operator shall be contactable 24 hours a day, 365 days a year. Specialist response shall be available on the next working day following a request from the DSO or TSO.

DCC11.5.2.6.2 For DSO Type A connected Wind Farm Power Stations a designated Responsible Operator shall be contactable by the DSO and TSO at all times to discuss operational matters without undue delay and in any case within 15 minutes. Following a request from the DSO, the Responsible Operator shall be present at the Wind Farm Power Station's Connection Point without undue delay and in any case within one hour and shall be capable of taking any required appropriate actions. The Responsible Operator shall be contactable 24 hours a day, 365 days a year.

DCC11.5.2.7 Data and Communications Specifications

DCC11.5.2.7.1 The location of the TSO Telecommunications Interface Cabinet shall be agreed between the DSO and the Wind Farm Power Station at least 120 business days prior to the Wind Farm Power Station's scheduled Operational Date. A standard interface for signals will be made available to the Wind Farm Power Station by the TSO.

DCC11.5.2.7.2 The necessary communications links, communications protocol and an individual Wind Farm Power Station signal list shall be specified by the TSO/DSO as appropriate, at least 120 business days prior to the Wind Farm Power Station's scheduled Operational Date. Current applicable standards shall apply and the accuracy class for signals shall comply with the prevailing European Standard at that time.

⁵ Refer to Table 5.

⁶ Refer to Table 5.

DCC11.5.2.7.3 For loss of communications links, persistence (i.e. continuing to operate with the most recent data set) shall be used in terms of set-points until the designated Responsible Operator has been contacted by the DSO/TSO as appropriate.

DCC11.5.2.7.4 If Active-Power Control, Frequency Response or Voltage Regulation facilities at the Wind Farm Power Station become unavailable, the Wind Farm Power Station shall contact TSO without undue delay.

DCC11.5.2.7.5 Where signals or indications required to be provided by the Wind Farm Power Station under DCC11.5 become unavailable or do not comply with applicable standards due to failure of the Wind Farm Power Station's technical equipment or any other reason under the control of the Wind Farm Power Station, the Wind Farm Power Station shall, acting in accordance with Good Industry Practice, restore or correct the signals and/or indications as soon as possible.

DCC11.5.2.8 Installation of MV recloser at Windfarm site
In order to provide adequate protection to MV networks connecting to the Wind Farm Power Station an MV recloser shall be installed in the DSO's Mv substation at the Wind Farm Power Station site.

DCC11.5.3 WIND POWER FORECASTS

MW forecasts shall be provided by Wind Farm Power Stations with an MEC in excess of 30 MW. These forecasts shall be provided at 10:00 a.m. on a daily basis for the following 48 hours for each 30 minute time-period, by means of an electronic interface in accordance with the reasonable requirements of TSO's data system.

DCC11.5.4 WIND FARM POWER STATION MW AVAILABILITY DECLARATIONS

Wind Farm Power Stations with an MEC in excess of 30 MW shall submit Wind Farm Power Station MW Availability Declarations whenever changes in Wind Farm Power Station Availability occur or are predicted to occur. These declarations shall be submitted by means of an electronic interface in accordance with the reasonable requirements of TSO's data system.

DCC11.6 DYNAMIC MODELS FOR WIND FARM POWER STATIONS

DCC11.6.1 Wind Turbine Generator Dynamic Models

The TSO requires suitable and accurate dynamic models for all Generators connected to, or applying for a connection to, the Transmission System or the Distribution System in order to assess reliably the impact of the Generator's proposed installation on the dynamic performance and security and stability of the power system.

Modelling requirements for thermal and hydro Generators are processed on the identification by the applicant of the relevant PSS/E⁷ library model and the provision of the applicable data parameters as set out in DCC11.3.4. Where there are no suitable library models available, specially written models are supplied. These are known as "user-written models".

⁷ PSS/E Power System Simulator for Engineering; the power system analysis software package used by the TSO.

DCC11.6.2 REQUIREMENT TO PROVIDE A DYNAMIC MODEL

Each Wind Farm Power Station with a Registered Capacity of 5MW or greater shall provide to the DSO, for onward transmission to the TSO, a dynamic model, or shall provide an unambiguous reference to a dynamic model previously provided to the DSO or the TSO, appropriate for the Wind Farm Power Station. If all the Wind Turbine Generators in the Wind Farm Power Station are not identical, the model shall incorporate separate modules to represent each type of Wind Turbine Generator. Appropriate data and parameter values must be provided for each model.

The model shall be provided in PSS/E format, or in such other format as may be agreed between the Wind Farm Power Station and the TSO.

The models for Wind Turbine Generators and the Wind Farm Power Station (computer software based on a mathematical representation of the behaviour of the machine) must be able to calculate how quantities such as active power output, reactive power output, turbine speed etc. vary as factors such as the voltage at the Connection Point change. They must take account of the inherent characteristics of the machines and the actions of the WTG control systems and any relevant Wind Farm Power Station control systems.

DCC11.6.3 COMPUTER ENVIRONMENT

The dynamic models must run on the PSS/E software for the Irish network. They must not require a simulation time step of less than 5 ms. Details of the current PSS/E version, computer platform, compiler version etc, will be provided by the TSO upon request. The TSO may from time to time request that the models be updated to be compatible with changes in the TSO's computing environment. Each Wind Farm Power Station shall ensure that such updated models are provided without undue delay.

DCC11.6.4 FEATURES TO BE REPRESENTED IN THE DYNAMIC MODEL

The dynamic model must represent the features and phenomena likely to be relevant to angular and voltage stability. These features include but may not be limited to:

- a) the electrical characteristics of the Generator;
- b) the separate mechanical characteristics of the turbine and the Generator and the drive train between them;
- c) variation of power co-efficient with pitch angle and tip speed ratio;
- d) blade pitch control;
- e) converter controls;
- f) reactive compensation;
- g) protection relays.

DCC11.6.5 MODEL AGGREGATION

For computational reasons, it is essential that the models of individual WTGs can be aggregated into a smaller number of models, each representing a number of WTGs at the same site. A representation of the collector network may be included in the aggregate model of the Wind Farm Power Station.

DCC11.6.6 MODEL DOCUMENTATION

The model should be fully documented. The documentation should describe in detail the model structure, inputs, outputs and how to set up and use the model and should be based on the documentation of standard PSS/E library models.

The TSO may, when necessary to ensure the proper running of its complete system representation or to facilitate its understanding of the results of a dynamic simulation, request additional information concerning the model, including the source code of one or more routines in the model. The Wind Farm Power Station shall comply with any such request without delay. Where the Wind Farm Power Station or any other party (acting reasonably) designates such information as confidential on the basis that it incorporates trade secrets, the DSO or TSO shall not disclose the information so designated to any third party.

DCC11.6.7 TIME TO COMPLY

Where a User requires reasonable time to develop the necessary model or models so as to comply fully with all the provisions in this section DCC11.6.2, the User may apply to the DSO to be deemed compliant with the provisions of DCC11.6.2 on the basis that the non-compliance will not unduly inhibit the assessment by the TSO of the stability and reliability of the power system and that the User has a satisfactory programme to remedy the non-compliance. The DSO shall refer any such application to the TSO for consideration. If the TSO is satisfied as to the User's programme for developing and testing the necessary dynamic model or models, the DSO and TSO may, for so long as the TSO is so satisfied, treat the User as being in compliance with the provisions of DCC 10.6.2. If the TSO decides, acting reasonably, that it is not satisfied as to the User's programme for developing and testing the necessary dynamic model and that the User cannot be deemed to be in compliance with DCC11.6.2, the User may apply for a derogation under the terms of DGC11.3.

DCC11.6.8 VALIDATION OF MODEL

All models provided to the DSO and TSO for use in dynamic simulations must be validated. The TSO must be satisfied that the behaviour shown by the model under simulated conditions is representative of the behaviour of the real equipment under equivalent conditions.

For validation purposes the Wind Farm Power Station shall ensure that appropriate tests are performed and measurements taken to assess the validity of the dynamic model. Where the validity of the model has not been confirmed prior to the commissioning of the Wind Farm Power Station, appropriate tests shall be carried out and measurements taken at the Wind Farm Power Station to assess the validity of the dynamic model. The tests and measurements required shall be agreed with the DSO and the TSO.

The Wind Farm Power Station shall provide to the DSO for onward transmission to the TSO all available information showing how the predicted behaviour of the dynamic model to be verified compares with the actual observed behaviour of a prototype or production WTG under laboratory conditions and/or actual observed behaviour of the real WTG as installed and connected to a transmission or distribution network.

If the on-site measurements or other information provided indicate that the dynamic model is not valid in one or more respects, the Wind Farm Power Station shall provide a revised model whose behaviour corresponds to the observed on-site behaviour as soon as reasonably practicable.

The conditions validated should as far as possible be similar to those of interest, e.g. low short circuit level at Connection Point, close up, severe faults, nearby moderate faults, remote faults, voltage excursions, frequency excursions, large wind speed variations.

DCC11.6.9 REQUIREMENTS FOR WIND FARM POWER STATION OF LESS THAN 5 MW

As an alternative to providing a dynamic model as specified in DCC11.6.2 to 10.6.8, a Wind Farm Power Station of less than 5 MW may provide to the DSO for onward transmission to the TSO the following information:

- Wind turbine generator type
(fixed speed stall regulated, fixed speed pitch regulated, fixed speed pitch regulated with variable rotor resistance, variable speed with doubly-fed induction generator, variable speed with synchronous generator and fully-rated converter or other specified type.)
- Manufacturer of wind turbine generator
- Model/type description
- Manufacturer of generator
- Turbine-generator data as set out in DCC11.3.1.
-

DCC11.6.10 WIND FARM DATA

In order to construct a valid dynamic model of each Wind Farm Power Station, the following Wind Farm Power Station data is required by the TSO:

Wind Turbine Generator (WTG) transformer

This is the transformer that connects the WTG with the internal Wind Farm Power Station network.

- Rating of WTG transformer (MVA or kVA)
- WTG transformer voltage ratio (kV)
- WTG transformer impedance (% on rated MVA or kVA)

Internal Wind Farm Power Station network and corresponding data

Details of the Wind Farm Power Station’s internal network (collector network) structure should be provided by means of a single-line diagram or other description of connections. The description should indicate how the individual WTGs are connected together as well as how they are connected to the Wind Farm Power Station substation. The different cable or overhead line types and the individual length of each section of circuit should be specified.

Electrical parameters of the cables or overhead lines in the collector network should be provided as set out in the table below:

| | Type1 | Type2 | Type3 | |
|--|-------|-------|-------|-----------------------------|
| Total length (m) | | | | Extend table as appropriate |
| Conductor cross section area per core (mm) | | | | |
| Conductor type (Al, Cu, etc) | | | | |
| Type of insulation | | | | |
| Charging capacitance (µF/km) | | | | |
| Charging current (Ampere/km) | | | | |
| Positive sequence resistance (R1 Ohm/km) | | | | |
| Positive sequence reactance (X1 Ohm/km) | | | | |

Connection point step up transformer

If there is a step-up transformer connecting the Wind Farm Power Station site with the Distribution System the following transformer data is required:

- Rating of step-up transformer (MVA or kVA)
- Transformer Voltage ratio (kV)
- Transformer impedance (% on rated MVA or kVA)

Reactive compensation installed at site

Number of inductive devices

For each device, the inductive kVAr or MVA capability. If the device has more than one stage please indicate the number of stages and the kVAr or MVA capability switched in each stage i.e. 0.5 MVA in 5 steps etc.

Number of capacitive devices

For each device, the capacitive kVAr or MVA capability. If the device has more than one stage please indicate the number of stages and the kVAr or MVA capability switched in each stage i.e. 0.5 MVA in 5 steps etc.

Method of voltage/reactive power control applied to each controllable reactive compensation device. This information should be provided in sufficient detail (e.g. transfer function block diagram, control system gain/droop, deadband and hysteresis characteristics, tap steps, etc.) to allow an appropriate dynamic model to be developed.

Distribution Operating Codes

DOC1 DISTRIBUTION OPERATING CODE 1 - DEMAND FORECASTING

DOC1.1 INTRODUCTION

DOC1.1.1 In order for the DSO to operate the Distribution System efficiently and to ensure maximum System security and System Stability, there is a need for those Users specified in DOC1.3 to provide loading and generation output information to the DSO.

DOC1.1.2 The Grid Code specifies the TSO requirements for Demand Forecasting for Users subject to Central Dispatch. Distribution Operating Code1 (DOC1) specifies the information to be provided to the DSO by other Users of the Distribution System so that these requirements can be met.

DOC1.1.3 The information to be provided under DOC1 is required to enable the DSO to maintain the integrity of the Distribution System.

DOC1.1.4 Where demand data is required from the User, this means the MW Demand of electricity at the Connection Point. The DSO may in certain cases specify that the Demand data shall include the MVA_r Demand.

DOC1.1.5 The means of providing the information to the DSO and its confirmation includes any non-transitory written form, or any other suitable means of electronic transfer which enables the recipient to retain information.

DOC1.2 OBJECTIVE

The objectives of DOC1 are to:

- (a) Set out the demand forecast and the generating Plant Output information to be provided by Users to enable the DSO to operate the Distribution System; and
- (b) Specify the information to be provided by Users to the DSO to enable it to comply with its obligations under the Grid Code.

DOC1.3 SCOPE

DOC1 applies to the following Users of the Distribution System:

- (a) Major Customers connected to the Distribution System and Medium Voltage Customers where the DSO considers it appropriate.
- (b) Generators with Generating Plant over 2MW.

DOC1.4 INFORMATION FLOW AND CO-ORDINATION

DOC1.4.1 The DSO shall co-ordinate Demand forecast information for each Bulk Supply Point to meet the requirements of the Grid Code (OC1). The DSO shall aggregate forecast information provided by Users, where appropriate, and provide forecast information to the TSO where Demand, or change in Demand, is greater than 4MW at any Connection Point.

DOC1.4.2 Generation information for Generating Plant in the Distribution System, which is not subject to Central Dispatch, shall be provided where specified to the DSO. Customers with CHP and Customers with Auto-production may also be required to supply information.

DOC1.4.3 Centrally Dispatched Users shall comply with the requirements of OC1 of the Grid Code. Information shall be provided directly to the TSO.

DOC1.5 DEMAND FORECAST DATA

- DOC1.5.1 Generating Units greater than 2MW and not subject to central dispatch shall provide to the DSO information regarding output and planned shutdowns for specified future periods. This shall be provided on an annual basis when requested by the DSO. The information required is given in Schedule 2 of the Distribution Data Registration Code (DDRC).
- DOC1.5.2 Major Customers shall provide to the DSO information regarding demand and planned shutdowns for specified future periods. This shall be provided on an annual basis when requested by the DSO. The information required is given in Schedule 2 of the Distribution Data Registration Code (DDRC).
- DOC1.5.3 Dispatchable Demand Customers shall provide to the DSO information regarding demand and planned shutdowns for specified future periods. This shall be provided on an annual basis when requested by the DSO. The information required is given in Schedule 2 of the Distribution Data Registration Code (DDRC).

DOC2 DISTRIBUTION OPERATING CODE 2 - OPERATIONAL PLANNING

DOC2.1 INTRODUCTION

DOC2.1.1 Distribution Operating Code 2 (DOC2) is concerned with the co-ordination of Planned Outages of Plant and Apparatus which affect the Operation of the Distribution System or require the commitment of DSO resources.

DOC2.1.2 DOC2 supplements the obligation of the DSO to provide certain information to the TSO under the Grid Code and establishes procedures to enable the collection of such data from Users specified in DOC2.3.

DOC2.1.3 The means of providing the information to the DSO and its confirmation includes any non-transitory written form, or any other suitable means of electronic transfer which enables the recipient to retain information.

DOC2.1.4 In order for the DSO to fulfil the requirements of this DOC2 it should be noted that the information set out in Grid Code (OC2), to be provided by the TSO will form the basis of Operational Planning under this DOC2.

DOC2.2 OBJECTIVE

DOC2.2.1 The objectives of DOC2 are to:-

- (a) set out the Operational Planning procedure and typical timetable for the co-ordination of outage requirements for Plant and Apparatus to be provided by Users to enable the DSO to operate the Distribution System.
- (b) specify the information to be provided by Users to the DSO to allow it to comply with the Grid Code.

DOC2.3 SCOPE

DOC2.3.1 DOC2 applies to the following Users of the Distribution System:

- (a) Major Customers connected to the Distribution System where the DSO considers it appropriate;
- (b) Generating Plant not subject to central dispatch;
- (c) Customers with CHP and Customers with Auto-production;
- (d) Centrally Dispatched Users

DOC2.4 PROVISION OF INFORMATION

DOC2.4.1 Information on Generating Plant not subject to central dispatch (including Customers with CHP and Customers with Auto-production) shall be provided, where specified, directly to the DSO. This information to be provided to the DSO is shown in Schedule 3(a) and Schedule 3(b) of the DDRRC.

DOC2.4.2 Centrally Dispatched Users shall comply with the requirements of OC2 of the Grid Code. Information shall be provided directly to the TSO.

DOC2.5 TIMESCALES AND DATA

DOC2.5.1 For Users that are not subject to Central Dispatch detailed implementation of data gathering and timescales shall be determined by the DSO and each User. Due recognition shall be given by the DSO to voltage levels and capacities of Plant and Apparatus when assessing information requirements.

DOC2.5.2 The information may be required for different timescales as may be determined by the TSO or the DSO planning needs.

DOC 2.5.3 For Users that are subject to Central Dispatch, implementation of data gathering and timescales shall be determined by the User, DSO and TSO. Due recognition shall be given by the DSO to voltage levels and capacities of Plant and Apparatus when assessing information requirements.

DOC2.6 INFORMATION FROM GENERATORS

DOC2.6.1 Information from Generating Plant greater than 2MW and not subject to central dispatch shall include details of planned outages for maintenance or other purposes as well as the expected time of return to service.

DOC2.6.2 The Generator shall not synchronise without first obtaining permission from the DSO unless prior agreement has been reached with the DSO.

DOC2.7 INFORMATION TO USERS

DOC2.7.1 The DSO shall advise Major Customers, Dispatchable Demand Customers or Generators who may be significantly affected by particular outages of Distribution Plant and Apparatus, of the likely dates and duration of the outages. If there are objections from Users these shall be considered by the DSO and alternative arrangements proposed if possible.

DOC5 DISTRIBUTION OPERATING CODE 5 - DEMAND CONTROL

DOC5.1 INTRODUCTION

DOC5.1.1 Distribution Operating Code 5 (DOC5) is concerned with provisions to be made by the DSO or Users of the Distribution System, in certain circumstances, to permit reductions in Demand in the event of insufficient Generating Plant and transfers from External Interconnections and Inter-Jurisdictional Tie-lines being available to meet Demand or to avoid disconnection of Customers or in the event of breakdown and / or operating problems (such as in respect of System Frequency, System Voltage levels or system thermal overloads) on any part of the Transmission or Distribution System.

DOC5.1.2 The Demand Control procedures ensure that hardship to Users and Customers is minimised and that in so far as is practicable, all parties affected are treated equitably.

DOC5.1.3 DOC5 deals with the following means of reducing Demand:

- (a) Automatic low frequency or voltage Demand disconnection;
- (b) Customer Demand reduction including Voltage Reduction;
- (c) Customer Demand management initiated by Suppliers or other parties, other than following an instruction by the TSO or the DSO;
- (d) Dispatchable Demand Customers
- (e) Customer Demand reduction instructed by the TSO or the DSO;
- (f) Emergency manual Demand disconnection;

The term Demand Control is used to describe any or all of these methods of achieving a Demand reduction.

DOC5.1.4 Where Demand Control is exercised by the DSO it shall be done in a manner that in so far as reasonably practicable does not discriminate against any customer or supplier and shall use reasonable endeavours to ensure that the burden is shared fairly among customers. Exemptions may apply to vital and priority customers as defined in the Distribution load shedding plan approved by the CER.

DOC5.2 OBJECTIVE

To establish procedures to enable the DSO, following an instruction of the TSO or otherwise to achieve a reduction in Demand that will either avoid or relieve operating problems on the Transmission System and / or the Distribution System, in whole or in part, in a manner that does not unduly discriminate against or unduly prefer any one or group of Suppliers or their Customers in accordance with the distribution licence.

DOC5.3 SCOPE

DOC5.3.1 DOC5 applies to the DSO and all Users of the Distribution System:-

DOC5.3.2 Implementation of Demand Control by the DSO may affect all Customers of Suppliers connected to the Distribution System and where applicable, contractual arrangements between Suppliers and their Customers may need to reflect this.

DOC5.4 METHODS OF DEMAND CONTROL

- DOC5.4.1 Customer Demand may be disconnected automatically at selected locations in accordance with the requirements of the Grid Code, in the event of a sudden fall in frequency. Such an arrangement shall be carefully co-ordinated as part of an overall scheme and may take into account any operational requirements or essential load.
- DOC5.4.2 Automatic disconnection by under voltage relay may be used to discriminately disconnect load at either 110kV, or 38kV or MV in order to maintain voltage within acceptable limits, so as to avoid widespread load shedding.
- DOC5.4.3 Deliberate reduction of voltage may be used to achieve a temporary reduction in load Demand.
- DOC5.4.4 Deliberate reduction in system frequency may also be used to achieve a temporary reduction in load Demand in accordance with the Grid Code.
- DOC5.4.5 Emergency manual load shedding may be carried out on the Distribution or Transmission Systems for reasons of shortfall in supply or other reasons.
- DOC5.4.6 In the event of a sustained period of shortfall then planned rota load shedding may be used to share the available power among affected Customers.

DOC5.5 IMPLEMENTATION OF DEMAND CONTROL

- DOC5.5.1 Where Demand Control is exercised by the DSO in order to safeguard the Distribution System, the DSO shall liaise with and inform Users accordingly as far as is practicable.
- DOC5.5.2 Where Demand Control is exercised by the DSO on instruction or request from the TSO in order to safeguard the Total System then the DSO is required to respond to these requests promptly but shall liaise with and inform other Users so far as is practical.
- DOC5.5.3 Procedures for load shedding including exemption policies, load shedding rotas and customer communications are contained in the Distribution load shedding plan approved by the CER.

DOC7 DISTRIBUTION OPERATING CODE 7 - OPERATIONAL COMMUNICATIONS AND LIAISON

DOC7.1 INTRODUCTION

Distribution Operating Code 7 (DOC7) sets out the requirements for the exchange of Information in relation to Operations and /or Events on the Distribution System or the Installation of any User connected to the Distribution System which have had or may have had, or will have or may have an Operational Effect on the Distribution System or the Installation of any other User.

DOC7.2 OBJECTIVE

To provide for the exchange of information so that the implications of the Operation and / or Event can be considered and the possible risks arising from it can be assessed and appropriate action taken by the relevant party in order to maintain the integrity of the Total System and the User's Installation. DOC7 does not seek to deal with any actions arising from the exchange of information, but merely with that exchange.

DOC7.3 SCOPE

DOC7 applies to the following Users of the Distribution System

- (a) Major Customers connected to the Distribution System where the DSO considers it appropriate;
- (b) Generating Plant with a capacity greater than 2MW;
- (c) Customers with CHP and Customers with Auto-production where the DSO reasonably considers it appropriate;
- (d) Dispatchable Demand Customers.

DOC7.4 PROCEDURE

DOC7.4.1 The DSO and Users connected to the Distribution System shall nominate persons and/or contact locations and agree communication channels for the necessary exchange of information to make effective the exchange of information required by DOC7.

DOC7.4.2 SCADA equipment may be required at a User's site for the transmission of information and data to and from the DSO or the TSO Control Centre. The requirement to provide this information shall normally be included in the relevant Connection Agreement.

DOC7.4.3 Information between the DSO and Users shall be exchanged on the reasonable request of either party. The request may follow a specific Operation, or be in accordance with a prior agreement to exchange information on particular types of Event.

This does not preclude the voluntary exchange of information which may be perceived as being relevant to the operation of the Distribution or User Installation, in accordance with Good Industry Practice.

DOC7.4.4 In the case of an Operation on the Distribution System or on receipt of notification of an operation on the Transmission System, which will have or may have, in the opinion of the DSO, an Operational Effect on the Installation of a User connected to the Distribution System, the DSO shall notify the User.

DOC7.4.5 In the case of an Operation on the Installation of a User connected to the Distribution System, which will have or may have an Operational Effect on the Distribution System, the User shall notify the DSO in accordance with DOC7.

DOC 7.4.6 In the case of an Operation on the Installation of a Centrally Dispatched User connected to the Distribution System, which will have or may have an Operational Effect on the Distribution System, the User shall notify both the DSO and TSO in accordance with DOC7.

DOC7.4.7 A Notification under DOC7 shall be of sufficient detail to describe the Operation, although it need not state the cause, and to enable the recipient of the notification reasonably to consider and access the implications and risks arising and shall include the name of the individual reporting the Operation. The recipient may ask questions to clarify the notification.

DOC7.4.8 A notification under DOC7 shall be given as far in advance as possible to allow the recipient to consider and assess the implications and risks arising.

DOC7.5 SIGNIFICANT INCIDENTS

DOC7.5.1 Where an event on the Distribution System has had or may have had a significant effect on the User's installation or where an event in the User's installation has had or may have had a significant effect on the Distribution System, the event shall be deemed to be a Significant Incident by the DSO in consultation with the User. Significant Incidents shall be reported in writing to the affected party in accordance with the provisions of DOC8.

DOC7.5.2 A Significant Incident shall include events which result in, or may result in, the following:

- (a) Voltage limits outside statutory limits
- (b) System frequency outside statutory limits; or
- (c) System stability failure

DOC8 DISTRIBUTION OPERATING CODE 8 -EVENT REPORTING

DOC8.1 INTRODUCTION

DOC8.1.1 Distribution Operating Code 8 (DOC8) sets out the requirements for reporting in writing those Events deemed to be "Significant Incidents" under DOC7.

Information between the DSO and major Users shall be exchanged on the reasonable request of both parties.

DOC8.1.2 DOC8 also provides for the joint investigation of Significant Incidents by the Users involved.

DOC8.2 OBJECTIVES

DOC8.2.1 The objective of DOC8 is to facilitate the provision of more detailed information in writing and where agreed between the DSO and the Users involved, joint investigation of those Significant Incidents reported verbally under DOC7.

DOC8.3 SCOPE

DOC8.3.1 DOC8 applies to the following Users of the Distribution System:

- (a) Major Customers connected to the Distribution System where the DSO considers it appropriate;
- (b) Generating Plant with a capacity greater than 2MW;
- (c) Customers with CHP and Customers with Auto-production where the DSO reasonably considers it appropriate;
- (d) Dispatchable Demand Customers.

DOC8.4 PROCEDURES

DOC8.4.1 The DSO and each User specified in DOC8.3.1 shall nominate officers and establish communication channels to ensure the effectiveness of this DOC8. Such officers and communication channels may be the same as those established under DOC7.

DOC8.4.2 Communication shall, as far as possible, be direct between the User and the operator of the Distribution System. However, this does not preclude communication with the Users nominated representative.

DOC8.4.3 In the case of an event which has been reported to the DSO under DOC7 and subsequently has been determined by the DSO to be a Significant Incident, a written report shall be given to the DSO by the User in accordance with DOC8.

DOC8.4.4 In the case of an event which has been reported to the User under DOC7 and subsequently has been determined by the DSO to be a Significant Incident, a written report shall be given to the User by the DSO in accordance with DOC8. In the case where the User is subject to Central Dispatch, the written report shall be shared with the TSO, where the DSO deems it to be appropriate.

- DOC8.4.5 A Report shall be in writing or in electronic form and shall be sent to the DSO or User, as the case may be. It shall contain confirmation of the notification given under DOC7 together with more details relating to the Significant Incident including information which has become known relating to the Significant Incident since the notification. The report shall, as a minimum, contain those matters specified in DOC8.6.
- DOC8.4.6 A report under DOC8 shall be given as soon as reasonably practical after the notification under DOC7.

DOC8.5 JOINT INVESTIGATIONS

DOC8.5.1 Where a significant Incident has been declared and a report submitted under DOC8 either party or parties may request in writing that a joint investigation be carried out.

DOC8.5.2 The composition of such an investigation panel shall be appropriate to the incident to be investigated and agreed by all parties involved.

DOC8.5.3 A joint investigation shall only take place where all parties affected by it agree to it. The form and rules of, and procedures for, and all matters relating to the joint investigation shall be agreed at the time of a joint investigation and in the absence of agreement the joint investigation shall not take place.

DOC8.6 MATTERS TO BE INCLUDED IN A WRITTEN REPORT OF A SIGNIFICANT INCIDENT

DOC8.6.1 Matters applicable to the DSO and Generators and Dispatchable Demand Customers:

- (a) Date and time of Significant Incident;
- (b) Location;
- (c) Equipment involved;
- (d) Brief description of Significant Incident;
- (e) Details of any Demand Control undertaken;
- (f) Conclusions and recommendations if applicable.

DOC8.6.2 Matters applicable to the DSO:

Effect on Users where appropriate:

- (a) Duration of incident; and
- (b) Estimated date and time of return to normal service

DOC8.6.3 Matters applicable to Generator:

Effect on generation including, where appropriate:

- (a) Generation interrupted;
- (b) Frequency response achieved;
- (c) MVAr performance achieved; and
- (d) Estimated date and return to normal service.

DOC8.6.4 Matters applicable to Dispatchable Demand Customers:

Effect on Demand including, where appropriate:

- (a) Demand Reduction Interrupted;
- (b) Duration of Incident
- (c) Estimated Date and Time of return to service.

DOC9 DISTRIBUTION OPERATING CODE 9 - SYSTEM TESTS

DOC9.1 INTRODUCTION

DOC9.1.1 Distribution Operating Code 9 (DOC9) sets out the responsibilities and procedures for arranging and carrying out System Tests which have or may have an effect on the Systems of the DSO or Users. System Tests are those tests which involve either simulated or the controlled application of irregular, unusual or extreme conditions on the Total System or any part of the Total System, but which do not include commissioning or re-commissioning tests or any other tests of a minor nature.

DOC9.2 OBJECTIVES

DOC9.2.1 The objectives of DOC9 are to :

- (a) ensure that the procedures for arranging and carrying out System Tests are such that, so far as practicable, System Tests do not threaten the safety of personnel or the general public and cause minimum threat to the security of supplies, the integrity of Plant or Equipment and are not detrimental to the DSO and Users; and
- (b) set out procedures to be followed for establishing and reporting System Tests.

DOC9.3 SCOPE

DOC9.3.1 DOC9 applies to the following Users of the Distribution System:

- (a) Major Customers connected to the Distribution System where the DSO considers it appropriate;
- (b) Generating Plant with a capacity greater than 2MW;
- (c) Customers with CHP and Customers with Auto-production where the DSO reasonably considers it appropriate.
- (d) Dispatchable Demand Customers

DOC9.4 PROCEDURES

DOC9.4.1 If the System Test is proposed by the DSO or the User connected to the Distribution System or if the test will or may have an affect on the Transmission System then the provisions of DOC9 or the Grid Code shall apply.

DOC9.4.2 System Tests which have a minimal effect on the Distribution System or the Systems of others will not be subject to this procedure; minimal effect shall be taken to mean variations in voltage, frequency and waveform distortion of a value not greater than those figures which are defined in the Distribution Planning Code.

DOC9.4.3 When the DSO or a User intend to undertake a System Test which may have significant effect on the System of others normally twelve months notice, or as otherwise agreed by the DSO, shall be given by the person proposing the System Test (Test Proposer) to the DSO and to those Users who may be affected by such a System Test.

- DOC9.4.4 The proposal shall be in writing and shall contain details of the nature and purpose of the proposed System Test and shall indicate the extent and situation of the Plant or Apparatus involved.
- DOC9.4.5 If the information set out in the proposal notice is considered insufficient by the recipient they shall contact the Test Proposer with a written request for further information which shall be supplied as soon as reasonably practicable. The DSO shall not be required to do anything under DOC9 until it is satisfied with the details supplied in the proposal or pursuant to a request for further information.
- DOC9.4.6 If the DSO wishes to undertake a System Test, the DSO shall be deemed to have received a proposal of that System Test.
- DOC9.4.7 The DSO shall have overall co-ordination of the System Test, using the information supplied to it under DOC9 and shall identify in its reasonable estimation, which Users other than the Test Proposer, may be affected by the proposed System Test.
- DOC9.4.8 Following receipt of the System Test proposal the DSO shall evaluate the impact of the System Test and discuss the proposals with Users identified as being affected.
- DOC9.4.9 Within one month of receiving the System Test proposal the DSO shall submit a report to the Test Proposer which shall contain:-
- (a) proposals for carrying out the System Test (including the manner in which it is to be monitored);
 - (b) an allocation of costs between the affected parties, (the general principle being that the Test Proposer will bear the costs); and
 - (c) such other matters that the DSO consider appropriate; outline the procedure to be followed and the proposed test schedule and advise of any costs.
- DOC9.4.10 The proposal report shall be submitted to all those who received a notice under DOC9.4.3.
- DOC9.4.11 If the proposal report (or a revised proposal report as agreed between the DSO and the Test Proposer) is approved by all recipients, the System Test can proceed.
- DOC9.4.4.12 At least one month prior to the date of the proposed System Test, the DSO shall submit to all recipients of the proposal notice a programme which in this DOC9 shall be called a final test programme stating the switching sequence and proposed timings, a list of those staff involved in carrying out the System Test (including those responsible for site safety) and such other matters as the DSO deem appropriate.
- DOC9.4.4.13 The final test programme shall bind all recipients to act in accordance with the provisions contained within the programme in relation to the proposed System Test.
- DOC9.4.14 At the conclusion of the System Test, the Test Proposer shall be responsible for preparing a written report (the "final report") of the System Test for submission to the DSO.
- DOC9.4.15 The final report shall include a description of the Plant and /or Apparatus, tested and of the System Test carried out, together with the results, conclusions and recommendation.
- DOC9.4.16 Results of tests shall be reported to relevant parties, taking into account confidentiality issues.
- DOC9.4.17 All system test procedures shall comply with all applicable legislation.

DOC10 DISTRIBUTION OPERATING CODE - MONITORING, TESTING AND INVESTIGATION

DOC10.1 INTRODUCTION

DOC10.1.1 In order to properly discharge its responsibilities in respect of safe, secure and economic operation of the Distribution System and in accordance with its licence conditions the DSO shall organise and carry out monitoring, testing and investigation on the effect of Users' electrical Apparatus or electrical Installation on the Distribution System.

DOC10.2 OBJECTIVE

DOC10.2.1 The objective is to specify the DSO requirements to test and /or monitor the Distribution System to ensure that Users are not operating outside the technical parameters required by the Distribution General Codes and Operating Codes.

DOC10.3 SCOPE

DOC10.3.1 DOC10 applies to the following Users of the Distribution System:-

- (a) all Generators.
- (b) all Customers who are connected to the Distribution System.

DOC10.4 PROCEDURES

DOC10.4.1 The DSO shall, from time to time, determine the need to test or monitor the quality of supply at various points on the Distribution System.

DOC10.4.2 In the case of a Centrally Dispatched User of the Distribution System, the TSO shall, from time to time, determine the need to test or monitor the functionality and operational response of the user. This testing and monitoring may be carried out at various points on the Distribution System, subject to the prior agreement between the DSO and TSO.

DOC10.4.3 The requirement for specific testing and /or monitoring may be initiated by the receipt of specific complaints as to the quality of supply on the Distribution System.

DOC10.4.4 Where testing or monitoring is required at the Connection Point with a User then the DSO shall advise the User involved and the DSO shall make available the results of such tests to the User. In the case of a Centrally Dispatched User, the DSO shall make available the results of such tests to the TSO on request.

DOC10.4.5 Where a User is found to be operating outside the technical limits specified in the Distribution General Code then the User shall rectify the situation or disconnect the apparatus causing the problem from its electrical System connected to the Distribution System immediately or within such time as agreed with the DSO. In the case of a Centrally Dispatched User, the DSO shall inform the TSO of the issue on request.

DOC10.4.6 Continued failure to rectify the situation shall result in the User being disconnected in accordance with the Connection Agreement.

DOC10.4.7 the DSO shall, from time to time, monitor the affects of the User on the Distribution System.

DOC10.4.8 The monitoring shall normally be related to the amount of Active Power and Reactive Power or flicker or harmonics transferred across the Connection Point.

- DOC10.4.9 Where the User is exporting or importing Active Power or Reactive Power in excess of those defined in the Connection Agreement or causing disturbances, the DSO shall inform the User and the User shall restrict the power transfer to within the specified parameters
- DOC10.4.10 The DSO may check from time to time that Users are in compliance with agreed protection requirements and protection settings.

DOC11 DISTRIBUTION OPERATING CODE - SAFETY CO-ORDINATION

DOC11.1 INTRODUCTION

DOC11.1.1 Distribution Operating Code 11 (DOC11) specifies the Safety Management System criteria to be applied by the DSO to meet statutory requirements and Distribution Licence conditions and obligations.

DOC11.1.2 Similar criteria and standards of Safety Management Systems shall be provided by other Users of the Distribution System when carrying out work or tests at the operational interface with the DSO.

DOC11.2 OBJECTIVES

DOC11.2.1 To lay down the safety management criteria to be applied to ensure safety of persons working on the Distribution System and at or across operational and Ownership Boundaries.

DOC11.3 SCOPE

DOC11.3.1 DOC11 specifies the Safety Management criteria that applies to the DSO and the following Users of the Distribution System

- (a) Generators.
- (b) Major Customers
- (c) Any other party reasonably specified by the DSO including Users connected at Medium or Low Voltage for appropriate sections of DOC11 when necessary.
- (c) Agents of the DSO or Users working on the Distribution System or at or across operational boundaries.
- (d) Centrally Dispatched Users

DOC11.4 PROCEDURES

DOC11.4.1 The Safety Management principles and procedures (Safety Management System) for ensuring the health and safety of all relevant personnel shall be specified by the DSO and Users for work on their respective Systems or Plant or Apparatus connected to them.

DOC11.4.2 There shall be joint agreement by the DSO and Users on which Safety Management System is to be used for sites or locations where an operational boundary exists and proper documentation of the safety precautions to be taken shall be maintained.

DOC11.4.2 There shall be written authorisation of personnel who do the work of control, operation, work or testing of Plant or Apparatus forming part of or connected to the Distribution System.

DOC11.4.3 There shall be joint agreement between the DSO and Users which specifies responsibility for system or control equipment which shall ensure that only one party is responsible for any item of plant or apparatus at any one time.

DOC11.4.4 The DSO and each User shall at all times have nominated a person or persons responsible for the co-ordination of safety on the respective systems.

DOC11.4.5 The DSO and each User shall maintain a suitable system of documentation which records all relevant operational events that have taken place on the Distribution System or other System connected to it and the co-ordination of relevant safety precautions for work.

DOC11.4.6 System diagrams which show sufficient information for control personnel to carry out their duties shall be exchanged between the DSO and User as required.

DOC11.5 SAFETY AT THE DSO / USER INTERFACE

DOC11.5.1 The following procedure set down the basic safety requirements at the operator and the DSO interfaces. These procedures are necessary to ensure the safety of all who may have to work at either side of the interface or on the interface (boundary).

- (a) Written Rules for Safe Working and Communicating Procedures shall be available and used by all persons who may have to work at or use the facilities provided at the Interface.
- (b) Electrical equipment connected to either side of the interface and interface equipment shall be under the control of a named person at either side.
- (c) Each item of equipment shall be controlled by only one identifiable person at any one time.
- (d) Adequate means of isolation shall be provided at the interface to allow work to be carried out safely at either side of the interface.
- (e) Where necessary to prevent danger adequate facilities for earthing shall be provided at either side of the interface to allow work to be carried out safely at the interface or at either side of the interface.
- (f) Adequate working space, adequate means of access and egress and, where necessary, adequate lighting shall be provided at all electrical equipment on or near which work is being done in circumstances which may cause danger.
- (g) All electrical equipment shall be suitably identified where necessary to prevent danger.
- (h) Electrical installations and equipment shall comply with the relevant Statutory Requirements as set down in SI No.44 of 1993. Part VIII, Regulations 33 to 53 (Item 12, Annex 1).

DOC11.6 SAFETY RULES

DOC11.6.1 Operation and Maintenance of the Users' equipment shall only be carried out by authorised personnel. Before first commissioning the plant, operating procedures shall be agreed with the DSO.

DOC11.6.2 Instructions for operating and / or earthing the Users' electrical equipment shall be clearly displayed in the Users' Medium and High Voltage switchroom.

DOC11.6.3 The ESB Networks Electrical Safety Rules detail the safety procedures to be observed for all personnel working on or in close proximity to Distribution System Plant or Equipment.

Distribution Data Registration Code

DDRC DISTRIBUTION DATA REGISTRATION CODE

DDRC1 INTRODUCTION

- DDRC1.1 The various sections of the Distribution Code require Users to submit data to the DSO.
- DDRC1.2 The Distribution Data Registration Code (DDRC) provides a series of schedule summarising all requirements for information of a particular type. Each User is then referred to the appropriate schedule for a statement of the total data requirements in his case.
- DDRC1.3 The DDRC specifies procedures and timings for the supply of data and subsequent updating. Where the timings are covered by detailed timetables laid down in other sections of the Distribution Code they are not necessarily repeated in full in the DDRC.
- DDRC1.4 In the case of a Generator seeking a connection to the DSO Distribution System then irrespective of the potential arrangements for scheduling and dispatch discussions on connection shall be with the DSO.

DDRC2 SCOPE

The Users to which the DDRC applies are:-

- (a) Generators;
- (b) Major Customers;
- (c) Medium Voltage Customer where the DSO considers it appropriate.
- (d) Centrally Dispatched Users.

DDRC3 PROCEDURES AND RESPONSIBILITIES

- DDRC3.1 Unless otherwise specified or agreed by the DSO each User shall submit data as defined in DDRC5 below and attached schedules.
- DDRC3.2 Data changes are reviewed annually to ensure continued accuracy or relevance. The DSO shall initiate this review in writing and the User shall respond in writing.
- DDRC3.3 Where possible data shall be submitted on standard forms forwarded to the User by the DSO.
- DDRC 3.4 If a User wishes to change any data item then this must first be discussed with the DSO in order for the implications to be considered and the change if agreed (such agreement not to be unreasonably withheld), be confirmed by the submission of a revised data form or by verbal means with confirmation in writing.
- DDRC3.5 From time to time the DSO may change its data requirements, appropriate Users shall be advised of these changes as they occur and with a reasonable timescale by which to reply.
- DDRC3.6 In the case of a Centrally Dispatched User, the same data shall be provided to both the DSO and TSO.

DDRC4 DATA TO BE REGISTERED

- DDRC4.1 The schedule numbering matches the Schedule numbering of the Grid Code and some schedules are not required within the Distribution Code.
- DDRC4.2 Schedules 1(a), 1(b), and 1(c) –Generator Technical Information.
- DDRC4.3 Schedules 1(d) and 1(e) – Wind Generation
- DDRC4.4 Schedules 1(f) – Centrally Dispatched Demand Customers
- DDRC4.5 Schedule 2 – Demand Forecasts – as described in DOC1, demand and generation forecasts for the Users defined in the Scope.
- DDRC4.6 Schedule 3 (a) and (b) – Operational Planning – as described in DOC2, outage planning information.
- DDRC4.7 Schedule 4 (a) and (b) – System design Information – comprising system technical data.
- DDRC4.8 Schedule 5 – Load Characteristics – comprising the forecast data for load points indicating for example, the maximum load, the equipment that comprises the load and the harmonic content of the load.

DDRC5 DATA SCHEDULES

The schedules applicable to each class of User are as follows:

| Schedule Number | Title | Applicable to: |
|------------------------|--|--|
| Schedule 1(a) | Generating unit data | Generators including Customers with CHP and Customers with Autoproduction |
| Schedules 1(b) | Generating unit data | Generators with parallel operation. |
| Schedule 1(c) | Generating unit data | Generators greater than 2MW. |
| Schedule 2 | Demand Forecasts | Generators greater than 2MW; Major Customers. Centrally Dispatched Users |
| Schedule 3(a) | Operational Planning (Outages) | Generators, |
| Schedule 3(b) | Operational Planning (Plant and Apparatus) | Major Customers, generators, Customers with CHP and Customers with Auto-production |
| Schedule 4(a) | System Design | Generator; Major Customers. MV Customers if advised by DSO |
| Schedule 4(b) | System Design | Generator Operating in Parallel |

Schedule 5

Load Characteristics

Generator;
Major Customers.

Schedule 1(a)

GENERATING UNIT DATA

For All Generators including Customers with CHP and Customers with Auto-production

| DATA DESCRIPTION | UNITS |
|-------------------------------|--------------|
| Site Details | Text |
| Contact Name | Text |
| Generator Make | Text |
| Type of Generating Unit | Text |
| Type of Prime Mover | Text |
| Anticipated Operating Regime | Text |
| Terminal Volts | kV |
| Rated kVA | kVA |
| Rated kW | kW |
| Maximum Active Power sent out | kW |
| Reactive Power required | kVAr |
| Fault Level Contribution | MVA |
| Method of Voltage Control | Text |
| Generator Transformer Details | Text |

Schedule 1(b)

GENERATING UNIT DATA

For Generators with Parallel Operation

| DATA DESCRIPTION | UNITS |
|---|--|
| Engineering Details to include: Relevant Voltage Levels Generator size and winding configuration Transformer size and, ratio, and winding configuration Circuit breaker location Maximum three phase short circuit level (amps) Location of alternate electricity supplies CT/VT ratios and locations Synchronising and interlocking arrangements Relay types and location Power Factor correction location | Text / Schematic Diagram |
| Inertia Constant | MW secs /MVA (Whole Machine) |
| Stator resistance | |
| Direct Axis Reactances | Sub-transient Transient Synchronous |
| Time Constants: Direct Axis | Sub-transient Transient |
| Zero Sequence | Resistance Reactance |
| Negative Sequence | Resistance Reactance |
| Generator Transformer | Resistance Reactance MVA Rating Tap Arrangement Vector Group Earthing |
| Impulse levels (BIL) and power withstands at each voltage level | Schedule |
| Fault current available due to metallic three phase short circuit at the main incoming circuit breaker | Calculation Sheet |
| Interface Arrangements | Text / Diagrams |
| Details protection circuit and trip circuit supervision | Text / Diagrams |
| Details of relays to be used including measuring range, proposed settings and calculations used to determine relay settings | Text |
| Details of Power Factor Correction | Text / Diagrams |

Schedule 1(c)

GENERATING UNIT DATA

For Generators Greater Than 2MW

| DATA DESCRIPTION | UNITS |
|---|--------------|
| Type of prime mover | Text |
| Rated MVA | |
| Type of excitation system | Text |
| Automatic Voltage Regulator | Diagram |
| A block diagram for the model of the AVR system including data on the gains forward and feedback time constants and voltage control limits. | Text |
| Speed governor and prime mover data | |
| A block diagram for the model of the generator plant governor detailing the governor flyball and system control and turbine rating and maximum Power. | Diagram |
| Capacity and standby Requirements | MW |
| Registered Capacity and minimum generation of each generating unit and power station. | |
| Generating unit and power station auxiliary demand (active and reactive power) at registered capacity conditions. | MW MVA |
| Generating Unit and power station auxiliary demand (active and reactive power) under minimum generation conditions. | MW MVA |

Schedule 1(d)

GENERATING UNIT DATA – DYNAMIC MODELS FOR WIND FARM POWER STATIONS

For all Wind Farm Power Stations
(As an alternative, Wind Farm Power Stations with a Registered Capacity of less than 5 MW may provide the data set out in Schedule 1(e)).

| DATA DESCRIPTION | UNITS |
|--------------------------|---|
| Dynamic Model | PSS/E format (or other format agreed with TSO) |
| Dynamic Model Parameters | As required by dynamic model |
| | |
| OR | |
| | |

Dynamic Model previously provided to DSO or TSO:

| | |
|--------------------------------|--|
| Title/version of dynamic model | |
| Date sent to TSO/DSO | |
| By whom sent | |
| To whom addressed | |
| Means of transmission | |

Schedule 1(e)

GENERATING UNIT DATA – DYNAMIC MODELS FOR WIND FARM POWER STATIONS

For all Wind Farm Power Stations with a Registered Capacity of less than 5 MW, where the data specified in Schedule 1(d) is not provided.

| DATA DESCRIPTION | UNITS |
|-------------------------------------|--|
| WTG Technology | Fixed speed stall regulated Fixed speed pitch regulated Fixed speed pitch regulated with variable rotor resistance Variable speed with doubly-fed induction generator Variable speed with synchronous generator and fully-rated converter Other |
| WTG Manufacturer | |
| WTG Manufacturer's Type Designation | |
| Generator Manufacturer | |
| Generator Parameters | As specified in Schedule 1(b) |

Schedule 1(f)

For All Centrally Dispatched Customers

For All Centrally Dispatched Customers excluding Dispatchable Demand Customer

| DATA DESCRIPTION | UNITS |
|---|--------------|
| Site Details | Text |
| Contact Name | Text |
| Generator Make (if appropriate) | Text |
| Type of Generating Unit (if appropriate) | Text |
| Type of Prime Mover (if appropriate) | Text |
| Anticipated Operating Regime | Text |
| Terminal Volts | kV |
| Rated MVA | MVA |
| Rated MW | MW |
| Maximum Demand Reduction (if appropriate) | MVA |
| Fault Level Contribution | MVA |
| Method of Voltage Control | Text |
| Generator Transformer Details | Text |
| Meter Registration ID (MPRN No.) | Text |

For each Dispatchable Demand Customer, the following information shall be provided:

| DATA DESCRIPTION | UNITS |
|---|--------------|
| (a) Name of Demand Side Unit | Text |
| (b) Location of Demand Site(s); | Text |
| (c) The name of the Distribution Station(s) to which the Demand Site(s) is/are normally connected | Text |
| (d) Total Demand Reduction Capability (MW) | MW |
| (e) Demand Reduction Capability from on-site generation | MW |
| (f) Demand Reduction Capability from avoided Demand consumption | MW; |
| (g) Annual Demand Profile. | MW |
| (h) Meter Identification (MPRN) | Text |

For each Dispatchable Demand Customer which represents an Aggregated Demand Site, the following additional information shall be provided:

| | |
|--|------|
| (i) Demand Reduction Capability per Individual Demand Site | MW: |
| (j) Demand Reduction Capability from generation per Individual Demand Site | MW |
| (k) Demand Reduction Capability from avoided Demand consumption per Individual Demand Site | MW |
| (l) Annual Demand Profile per Individual Demand Site | MW |
| (m) Meter Identification (MPRN) | Text |

Schedule 2

DEMAND FORECASTS

(A) Generating Units greater than 2MW not subject to central dispatch

| DATA DESCRIPTION | Year 0 | Year 1 | Year 2 | Year 3 | Year 4 | Year 5 |
|--|---------------|---------------|---------------|---------------|---------------|---------------|
| Electricity Output (annual half-hour maximum active power output (MW)) | | | | | | |
| Forecast Electricity Generation (MWh) | | | | | | |
| Planned shutdown periods Date: start of shutdown | | | | | | |
| Planned shutdown periods Date: end of shutdown | | | | | | |

Note: Year 0 is current year.

(B) Major Customers and Medium Voltage Customers where the DSO considers it appropriate

| DATA DESCRIPTION | Year 0 | Year 1 | Year 2 | Year 3 | Year 4 | Year 5 |
|---|---------------|---------------|---------------|---------------|---------------|---------------|
| Electricity Demand (annual half-hour maximum power out (MW) and Power Factor) | | | | | | |
| Annual Energy forecast requirement (MWh) | | | | | | |
| Planned shutdown periods Date: start of shutdown | | | | | | |
| Planned shutdown periods Date: end of shutdown | | | | | | |

Note: Year 0 is current year.

(C) Centrally Dispatched Demand Customers:

| Data Description | Year 0 | Year 1 | Year 2 | Year 3 | Year 4 | Year 5 |
|---|---------------|---------------|---------------|---------------|---------------|---------------|
| Electricity Demand (annual half-hour Max Power in (MW). | | | | | | |
| Annual Energy forecast requirement (MWh) | | | | | | |
| Planned Shutdown periods Date: start of shutdown | | | | | | |
| Planned shutdown periods Date: end of shutdown | | | | | | |

Schedule 3(a)

OPERATIONAL PLANNING--SCHEDULED OUTAGES

For Generators and Centrally Dispatched Users.

| DATA DESCRIPTION | UNITS | TIME PERIOD | TYPE OF DATA |
|---|--------------|--------------------|------------------------------|
| For individual Generating Units the unit number and Generating Plant Capacity. Preferred outage dates earliest start date latest finish date. | MW | 0 to 52 weeks | Committed Outage Programme |
| For individual Generating Units the unit number and Generating Plant Capacity. Preferred outage dates earliest start date latest finish date. | MW | Years 2 to 3 | Provisional Outage Programme |
| For individual Generating Units the unit number and Generating Plant Capacity. Preferred outage dates earliest start date latest finish date. | MW | Years 4 to 7 | Indicative Outage Programme |

Schedule 3(b)

OPERATIONAL PLANNING

Plant and Equipment

For Generators and Major Customers, Customers with CHP and Customers with Auto-production and Centrally Dispatched Users.

| DATA DESCRIPTION | UNITS | Time Period Covered |
|--|--------------|----------------------------|
| Users provide the DSO and Centrally Dispatched Users provide the TSO with details of proposed outages which may affect the performance of the Distribution System with details of proposed outages which may affect the performance of the Distribution System, Details of trip testing, risks of the trip and other information where known which may affect the security and stability of the Distribution System | Dates | 0 to 52 weeks |
| Users provide the DSO and Centrally Dispatched Users provide the TSO with details of proposed outages which may affect the performance of the Distribution System, with details of proposed outages which may affect the performance of the Distribution System, Details of trip testing, risks of the trip and other information where known which may affect the security and stability of the Distribution System | Dates | Years 1 to 2 |

Schedule 4(a)

SYSTEM DESIGN INFORMATION

Generators and Major Customers, MV Customers and Centrally Dispatched Users if advised by DSO

| DATA DESCRIPTION | UNITS |
|---|------------------|
| <i>Reactive Compensation</i> | |
| Reactance of any capacity or banks and any series reactors | X |
| Rating of individual shunt reactors (not associated with cables) | MVA _r |
| <i>Rating of individual capacitor banks</i> | MVA _r |
| Details of any <i>automatic control logic</i> such that operating characteristics can be determined. | Text / Diagrams |
| <i>Point of connection to the system</i> | |
| <i>Lumped Network Susceptance</i> | MVA _r |
| Details of the equivalent lumped network susceptance of the User Installation referred back to the connection with the Distribution System. | |
| Including: | |
| shunt reactors which are an integrated part of a cable system and which are not normally in or out of service independent of the cable. | |
| Excluding: | |
| independently switched reactive compensation connected to the User Installation | |
| and | |
| any susceptance of any User Installation inherent in the active and reactive Demand. | |
| <i>Fault Infeeds</i> | |
| Maximum and minimum short circuit infeeds into the system | R+jX |
| <i>X/R ratio under maximum and minimum short circuit conditions</i> | |
| (Contribution from rotating plant) | |
| <i>Equivalent network information at the request of the DSO</i> | |
| <i>Interconnection Impedance</i> | |

Schedule 4(b)

SYSTEM DESIGN INFORMATION

For Generators and Centrally Dispatched Users Operating in Parallel with the System

DATA DESCRIPTION

UNITS

Interconnection Impedance:

| | |
|------------------------------|---|
| Positive Sequence Resistance | % |
| Zero Sequence Resistance | % |
| Positive Sequence Resistance | % |
| Zero Sequence Resistance | % |
| Susceptance | |

If the DSO considers that the impedance is low, then more detailed information will be requested.

Circuit Parameters Text / Diagrams

Switchgear Text / Diagrams

Protection Arrangements Text / Diagrams
Protection Settings

Transient Over-voltage Effects

Schedule 5

LOAD CHARACTERISTICS

For Generators, Major Customers and Centrally Dispatched Users

| DATA DESCRIPTION | UNITS |
|---|----------------------|
| <i>Types of Demand:-</i> Maximum Active Power Demand Maximum and minimum Reactive Power requirement | KW KVAr |
| <i>Type of Load and Control Arrangements:</i> Type of starter employed; Controlled Rectifiers; Large motor drives; | Text / Diagram |
| Maximum load on each phase at the time of maximum demand | Amps/Phase |
| Maximum phase unbalance | Amps/ Phase |
| Maximum harmonic content | % of harmonic number |
| <i>Fluctuating Loads:-</i> Rate of change of active and reactive power both increasing and decreasing | W/Sec KVAr/Sec |
| Shortest repetitive time interval between Fluctuation in active and reactive power | Secs |
| Largest step change in active and reactive power both increasing and decreasing | KW KVAr |
| <i>Disturbing Loads:</i> | Text |

Schedule 6

DSO standard practice currently requires that, unless otherwise agreed with the DSO, the following standards shall apply:

- | | |
|--|--|
| (a) Generation Units: | For Hydro and Wind: G1, G2, etc For Thermal: U1, U2, etc |
| (b) Generator Transformers (i.e. Transformers for Generation Unit Production) | at 110kV; T101, T102, etc |
| (c) Power Station Transformers (i.e. dedicated transformers supplying both the Generation Unit and the Power Station auxiliaries from the HV busbar) | at 110kV: ST101, ST102, etc |
| (d) Unit Transformers (i.e. transformers supplying auxiliaries of a Generation Unit) | UT1, UT2, etc |
| (e) Load Transformers | for 110/38kV: T141, T142, etc For 110/20kV: T121, T122, etc For 110/11kV and below: T101, T102, etc |
| (f) Bus Sections, conventional busbars | Single bus; A1, A2, etc Double Bus; A1, A2, B1, B2, etc |
| (g) Bus sections, ring busbars: | each section identified by designation Of Plant and/or Apparatus item connected To it. |
| (h) Bus Couplers | K1, K2, etc |
| (i) Line and cables | each line or cable at a station identified name of station or stations at the remote end or ends of the line or cable in alphabetical order. |
| (j) Circuit Breakers | CB |
| (k) Main Earth Disconnects | DE |
| (l) Line Disconnects | DL |
| (m) Busbar Disconnects | DA, DB, etc |
| (n) Coupler Disconnects | DA, DB, etc |

Glossary and Definitions

In the **Distribution Code** the following words and expressions shall, unless the subject matter or context otherwise requires or is inconsistent therewith, bear the following meanings:

| | |
|---------------------------------------|---|
| AC | Alternating Current. |
| Act | The Electricity Regulation Act 1999. |
| Active Power | The product of voltage and the in-phase component of alternating current (normally measured in kilowatts (kW) or megawatts (MW)). |
| Active Power Control | The automatic change in Active Power output from a Wind Farm Power Station in a response to an Active Power Control Set-Point received from the TSO. |
| Active-Power Control Set-point | The maximum amount of Active Power in MW, set by the TSO, that the Wind Farm Power Station is permitted to export. |
| Aggregated Demand Site | A group of Individual Demand-Sites represented by a Dispatchable Demand Customer, which together are capable of a Demand Reduction Capability equal to or above 4 MW (and which is therefore subject to Central Dispatch from the TSO). Each Individual Demand Site comprising an Aggregated Demand Site shall be in one currency zone. Unless otherwise specified, information submitted in respect of an Aggregated Demand Site shall always be at an aggregated level. |
| Available Active Power | The amount of Active Power that the Wind Farm Power Station could produce based on current wind conditions. The Available Active Power shall only differ from the actual Active Power if the Wind Farm Power Station has been curtailed, constrained or is operating in a restrictive Frequency Response mode. |
| Availability Notice | A notice to be submitted to the TSO pursuant to SDC1.4.1.1 of the Grid Code. |
| AVR | Automatic Voltage Regulation |
| Back-up Protection | That Protection system which will open a Circuit Breaker or other fault-current interrupting device in the absence of the current Protection operation of another Protection system. |
| Black Start shutdown. | The procedure necessary for recovery from a Total or Partial System shutdown. |
| Bulk Supply Point | A point of connection between the Transmission System and the Distribution System or between the Transmission System and a directly connected customer. |
| CCGT Installation | A collection of Generating Units comprising one or more Combustion Turbine Units and one or more Steam Units where, in normal operation, the waste heat from the Combustion Turbine Unit is passed to the water/steam system of the associated Steam Units and where the component Generating Units within the CCGT Installation are directly connected by steam or hot gas lines which enable those Units to contribute to the efficiency of the combined cycle operation of the CCGT Installation |
| CCGT Unit | A Generating Unit within a CCGT Installation. |

| | |
|--|---|
| CENELEC | European Committee for Electrotechnical Standardisation. |
| Central Dispatch | The Dispatch of Users by the TSO. |
| Centrally Dispatched Generating Units | Generating Units subject to Central Dispatch by the TSO. |
| Centrally Dispatched Users | Users subject to Central Dispatch by the TSO. |
| Circuit Breaker | A mechanical switching device, capable of making, carrying and breaking currents under normal circuit conditions and also of making, carrying for specified time and breaking currents under specified abnormal circuit conditions, such as those of short circuit. |
| CHP | The simultaneous production of utilisable heat and electricity from an integrated thermo-dynamic process. |
| Combustion Turbine Unit | A Generating Unit which compresses the inlet air and feeds fuel to the combustion chamber. The fuel and air burn to form hot gases which in turn forces these hot gases into the turbine, causing it to spin. The turbine can be fuelled by natural gas, by distillate or by other such fuels as technology may allow. |
| Commission | The Commission for Energy Regulation as established by the Electricity Regulation Act 1999. |
| Commissioning | The final process of testing part of a System prior to that part of the System being considered suitable for normal use. |
| Connection Agreement | An agreement between the DSO and each User setting out terms relating to a connection with the Distribution System . |
| Connection Point | The physical point at which a User's Plant or apparatus is joined to the Distribution System. |
| Contiguous Wind Farm Site | <p>A geographical area containing a number of Wind Farm Power Stations with signed DSO connection agreements, where any individual wind turbine generator on a Wind Farm Power Station site with a signed DSO connection agreement is within 1.5 kilometre of any individual wind turbine generator on another separate Wind Farm Power Station site with a signed DSO connection agreement.</p> <p>A proposed Wind Farm Power Station will be deemed to be considered part of a Contiguous Wind Farm Site where any individual wind turbine generator on the proposed Wind Farm Power Station site is within 1.5 kilometre of any individual wind turbine generator on a second Wind Farm Power Station site, where that second Wind Farm Power Station has a signed DSO connection agreement.</p> |
| Controlled Active-Power | The amount of Active Power that a Wind Farm Power Station is permitted to export based on the Active-Power Control Set-point signal sent by the TSO. |

| | |
|--|--|
| Controllable WFPS | A site containing at least one WTG can automatically act upon a remote signal from the TSO to change its Active Power output. |
| Controllable WFPS Availability | The amount of MW the Controllable WFPS can produce given favourable wind conditions. |
| Controllable WFPS MW Availability Declaration | A measure of the maximum Active Power which can be produced by a Controllable WFPS given favourable wind conditions. Account shall be taken of partial and/or full outages of individual WTG within the Controllable WFPS. |
| Controlled Active Power | The amount of Active Power that a Controllable WFPS is permitted to export based on the Active Power Set-point signal sent by the TSO. |
| Control Facility | A location used for the purpose of monitoring, control and operation of the User's Plant and Apparatus. |
| Customer | A User whose premises is connected to the Distribution System for the purpose of obtaining a supply of electricity at that premises. |
| Customer with Auto-production | A Customer generating electricity for his or her own use. |
| DC | Direct Current |
| Demand | Unless otherwise stated, the demand expressed in MW or MVar of Active Power and Reactive Power respectively. |
| Demand Profile | The estimated consumption of MW Demand for an Individual Demand Site or aggregated consumption for each Individual Site which form part of a Aggregated Demand Site for each Trading Period in the following Optimisation Time Horizon Period and which must be submitted to the TSO in the Availability Notice under SDC1.4.1.2 of the Grid Code. |
| Demand Reduction | The reduction in MW Demand which can be achieved in one currency zone by a Demand Side Unit or Aggregated Demand Side Unit for each Trading Period in the following Optimisation Time Horizon Period and which must be submitted to the TSO in an Availability Notice under SDC1.4.1.2 of the Grid Code. |
| Demand Reduction Capability | The reduction capability in MW Demand that can be achieved by the Demand Side Unit |
| Demand Side Unit | An Individual Demand Reduction Site or Aggregated Demand Site with a Demand Reduction Capability of at least 4 MW. The Demand Side Unit shall be subject to Central Dispatch. |
| Demand Site | A premises owned by a Customer connected to the Distribution System with a Demand Reduction capability. The Demand Site shall have a Maximum Import Capacity and shall not have a Maximum Export Capacity. |

| | |
|--|--|
| Disconnecter | A device which provides in the open position a means of disconnecting apparatus from the Distribution System in accordance with specified requirements. |
| Dispatch | The issue of instructions for Generating Units to achieve specific Active Power and Reactive Power outputs within Registered Data parameter and by stated times. |
| Dispatchable Demand Customer | A person who operates a Demand Side Unit, with a Demand Reduction Capability not less than 4MW, and is subject to the Distribution Code pursuant to any agreement with the DSO or otherwise. |
| Distribution Code | This document produced by ESB pursuant to the Electricity Regulation Act 1999. |
| Distribution Code Review Panel or Panel | The panel with the functions set out in DGC7. |
| Distribution Data | That portion of the Distribution Code which is identified as the Distribution Data |
| Registration Code | Registration Code. |
| Distribution General Conditions | That portion of the Distribution Code which is identified as the Distribution Operating Code. |
| Distribution Licence | The licence issued to ESB to distribute electricity. |
| Distribution Planning Code | That portion of the Distribution Code which is identified as the Distribution Planning Code. |
| Distribution Connection Code | That portion of the Distribution Code which is identified as the Distribution Connection Code. |
| Distribution System | The system which consists of electric lines, electric plant, transformers and switchgear and which is used for conveying electricity to final customers. |
| Distribution System Operator | ESB in its capacity as the licensed operator responsible for the ownership, maintenance and development of the Distribution System. |
| Distribution Use of System | The agreement between the DSO and Suppliers for transport of electricity Agreement from the Transmission System or Generators and Centrally Dispatched Users through the Distribution System to Customers. |
| Disturbing Loads | Loads which have the potential to introduce harmonics, flicker or unbalance into the system. |
| Earthing | A way of providing a connection between conductors and earth by an earthing device. |
| Earthing Device | A means of providing a connection between a conductor and earth of adequate strength and capability for the intended purpose. |

| | |
|----------------------------------|--|
| Equipment | Plant and/or Apparatus. |
| ESB Safety Rules | A document prepared by ESB and entitled “Electricity Supply Board, Ireland, Safety Rules (electrical), (Transmission, Distribution and Marketing)” and “Electricity Supply Board Ireland, Safety Rules (electrical), (Generating Stations)”. |
| ESI | Electricity Supply Industry. |
| ETCI | Electro Technical Council of Ireland |
| Event | An unscheduled or unplanned occurrence on or relating to a System including, without limiting that general description, faults, incidents and breakdowns. |
| Fault level | Prospective current that would flow into a short circuit at a stated point on the System and which may be expressed in kA or, if referred to a particular voltage, in MVA. |
| Flicker | Impression of unsteadiness of visual sensation induced by a light stimulus whose luminance or spectral distribution fluctuates with time. |
| Frequency | The number of Alternating Current cycles per second, expressed in Hertz at which the System normally operates, i.e 50 Hertz. |
| Frequency Response | The automatic adjustment of Active Power output from a Generation Unit(s) in response to Frequency changes. |
| Frequency Response System | A facility providing the means to automatically adjust the Active Power output from a Generation Unit(s) in response to changes in Frequency. |
| Generating Plant | A Power Station including any Generating Unit therein. |
| Generating Unit | Any apparatus which produces electricity. |
| Generator | A person who generates electricity under licence or exemption under the Act. |
| Good Industry Practice | The standard of practice attained by exercising that degree of skill, diligence, prudence and foresight which would reasonably and ordinarily be expected from a skilled and experienced operator engaged in the same type of undertaking under the same or similar circumstances. |
| Grid Code | The code produced by Eirgrid pursuant to the Electricity Regulation Act 1999 and any amendments thereto. |
| Grid Connected | Any Plant or Apparatus connected to the Transmission System is referred to as being Grid Connected. |

| | |
|---------------------------------------|---|
| Harmonics | Sinusoidal currents with a frequency equal to an integer multiple of the fundamental frequency of the connection voltage. |
| High Voltage (HV) | A voltage, used for the supply of electricity, whose lower limit of nominal rms value is greater than 35kV. |
| IEC | International Electrotechnical Commission. |
| Individual Demand Site | A single premises of a Demand Customer connected to the Distribution System with a Demand Reduction Capability. The Individual Demand Site shall have a Maximum Import Capacity and shall not have a Maximum Export Capacity. |
| Initial Demand Reduction | The Demand Reduction of a Demand Side Unit following a Dispatch Instruction from the TSO when the Demand Reduction is at 0 MW for a period greater than 24 Hours |
| Initial Demand Reduction Time | The time as specified by the Dispatchable Demand Customer in the Technical Parameters and is the time it takes for the Dispatchable Demand Customer to be able to implement the Initial Demand Reduction from receipt of the Dispatch Instruction from the TSO. |
| Inter-Jurisdictional Tie-lines | The lines, facilities and equipment that connect the Transmission System of the Republic of Ireland to the Transmission System of Northern Ireland. |
| Isolated | Disconnected from associated Equipment by a Disconnecter or adequate physical separation. |
| kVA | Kilovolt-amp |
| Low Voltage | A voltage, used for the supply of electricity, whose upper limit of nominal rms value is 1kV. |
| Major Customer | A customer who is connected to the Distribution System at High Voltage (voltage greater than 35kV). |
| Maximum Down Time | The maximum period of time during which Demand Reduction at a Demand Side Unit can be Dispatched. |
| Max Ramp Down Rate | The maximum Ramp Down Rate of a Demand Side Unit. In the case of a Demand Side Unit which consists of an Aggregated Demand Site this shall be the aggregated maximum Ramp Down Rate of the Individual Demand Sites. |
| Max Ramp Up Rate | The maximum Ramp Up Rate of a Demand Side Unit. In the case of a Demand Side Unit which consists of an Aggregated Demand Site this shall be the aggregated maximum Ramp Up Rate of the Individual Demand Sites. |
| Medium Voltage | A voltage, used for the supply of electricity, whose nominal rms value lies between 1kV and 35kV. |

| | |
|--------------------------------------|--|
| Meteorological Mast | A device erected at the Wind Farm Power Station site which has the capability measure representative wind speed, wind direction, air temperature and air pressure to a degree of accuracy corresponding to the appropriate prevailing European Standard at that time. |
| Metering Point | Has the meaning given to that term in the Registration Agreement. |
| Minimum Down Time | The minimum period of time during which Demand Reduction at a Demand Side Unit can be Dispatched |
| MVA | Megavolt-amp |
| MVA_r | Megavar (1,000,000 vars). |
| MW | Megawatt (1,000,000 watts). |
| National Control Centre (NCC) | The TSO's National Control Centre, as notified by the TSO to the Generator from time to time |
| Operating Reserve | The additional MW output required from Generating Units (or Demand Reduction) which must be realisable in real time operation to contain and correct any potential Total System Frequency deviation to an acceptable level. It will include Primary Operating Reserve, Secondary Operating Reserve and Tertiary Operating Reserve. |
| Operation | A scheduled or planned action carried out on a System. |
| Operational Effect | Any operation which causes the Transmission System or the Distribution System, or the system of other Users, to operate (or be at a materially increased risk of operating) differently from the way in which they would or may have operated in the absence of such effect. |
| Ownership Boundary | The boundary between the Distribution System and Equipment owned by the User. |
| Point of Common Coupling | The point on the Distribution System which is electrically nearest to the connection point and from which other customers' loads are, or may be, connected. |
| Planned Outage | An outage of Generating Plant or of part of the Transmission System or of part of the Distribution System other than a forced outage. |
| Plant | Fixed and movable items used in the generation and/or supply and/or transmission of electricity other than Apparatus. |
| Power Station | An installation consisting of Generating Unit(s) |

| | |
|--|--|
| Primary Operating Reserve (POR) | The additional MW output (and/or reduction in Demand) required at the Frequency nadir (minimum), compared to the pre-incident output (or Demand) where the nadir occurs between 5 and 15 seconds after an event. If the actual Frequency nadir is before 5 seconds or after 15 seconds after the event, then for the purpose of POR monitoring the nadir is deemed to be the lowest Frequency which occurred between 5 and 15 seconds after the event. |
| Protection | The provisions for detecting abnormal conditions in a System and initiating fault clearance or actuating signals or indications. |
| Reactive Power | The product of voltage and current and the sine of the phase angle between them which is normally measured in Kilovars (kVAR) or Megavars (MVAR). |
| Registered Capacity | The normal full load capacity of a Generating Unit as declared by the Generator less the MW consumed when producing the same. |
| Registered Data | Data referred to in the schedules to the Data Distribution Registration Code. |
| Remote Terminal Unit (RTU) | A device that collects, codes and transmits data. An RTU collects information from a master device and implements processes that are directed by that master. RTUs are equipped with input channels for sensing or metering, output channels for control, indication or alarms and a communications port. |
| Safety Management | The procedure adopted by the DSO or a User to ensure the safe Operation of its System and the safety of personnel required to work on that System. |
| Safety Procedures | The procedures specified within a Safety Management System. |
| SCADA Scheduling | Supervisory Control and Data Acquisition The procedure for determining intended usage of Generating Plant. |
| Secondary Frequency Regulation Systems (SFRS) | A control system installed between the NCC and a Power Station whereby MW set points can be adjusted remotely by the TSO to reflect the Dispatch Instruction. |
| Secondary Operating Reserve (SOR) | The additional MW output (and/or reduction in Demand) required compared to the pre-incident output (or Demand), which is fully available by 15 seconds from the time of the start of the Frequency fall and sustainable up to 90 seconds following an Event. |
| SFRS Control Range | The range of loads over which SFRS may be applied. |
| SFRS Maximum Load | The upper limit of the SFRS Control Range |
| SFRS Minimum Load | The lower limit of the SFRS Control Range. |

| | |
|---|--|
| Single Electricity Market (SEM) | The wholesale all-island single electricity market established and governed pursuant to the relevant legislation and the Trading and Settlement Code |
| Significant Incident | Events which have had or may have an operational effect on the Transmission or Distribution System or a Users Installation. |
| Steam Unit | A Generating Unit whose prime mover converts the heat-energy in steam to mechanical energy. |
| Step up Transformer | |
| Step Change | A step change is defined as a single, rapid change of the RMS voltage. Distribution System Voltage step changes can occur due to switching in and out of capacitors, lines, cables, transformers and other plant. |
| Superimposed Signals | Those electrical signals carried on a Distribution System for the purposes of information transfer. |
| Supplier | A person authorised by licence under section 14(1)(b), (c) or (d) or Section 14(2) of the Act to supply electricity to the connection point under a supply agreement. |
| System Stability | The state of the System whereby predicted changes in load and generation can be accommodated without any detrimental effect on the System. |
| System Tests | Those tests which involve simulating conditions or the controlled application of irregular, unusual or extreme conditions on the Total System or any part of it, but not including routine testing, commissioning or re-commissioning tests. |
| Tertiary Operating Reserve band 1 (TOR1) | The additional MW output (and/or reduction in Demand) required compared to the pre-incident output (or Demand), which is fully available and sustainable from 90 seconds to 5 minutes following an Event. |
| Tertiary Operating Reserve band 2 (TOR2) | The additional MW output (and/or reduction in Demand) required compared to the pre-incident output (or Demand), which is fully available and sustainable from 5 minutes to 20 minutes following an Event |
| Total System | The Transmission System, Distribution System and all User Systems within the Republic of Ireland |
| TN-C-S | A system of earthing as described in the National Rules for Electrical Installations (RT101) published by the Electro Technical Council of Ireland. |
| Transmission System | The system which consists wholly or mainly of high voltage lines and electric plant and which is used for conveying electricity from a generating station to a substation, from one generating station to another, or to any interconnector or to a final customer but shall not include any such lines which the board may, from time to time, with the approval of the commission, specify as being part of the Distribution System. |

Transmission System Operator (TSO) Eirgrid in its capacity as licensed operator of the Transmission System.

TSO Telecommunication Interface Cabinet The physical interface point between the TSO's telecommunications equipment and the Wind Farm Power Station's control equipment.

Unbalance (see Voltage Unbalance).

User A term used in various sections of the Distribution Code to refer to the persons using the ESB Distribution System, more particularly identified in each section of the Distribution Code.

Voltage Dip A sudden reduction of the voltage to a value between 90% and 1% of the declared voltage followed by a voltage recovery after a short period of time.

Voltage Fluctuations A series of rapid voltage changes which may be regular or irregular.

Voltage Reduction The method to temporarily control Demand by reduction of System voltage.

Voltage Regulation The automatic adjustment of Reactive Power output from a Generation Unit(s) in response to Voltage changes.

Voltage Regulation Set-point The voltage in kV that the Voltage Regulation System will act to regulate by continuous modulation of the Wind Farm Power Station's Reactive Power.

Voltage Regulation System A facility providing the means to automatically adjust the Reactive Power output from a Generation Unit(s) in response to changes in Voltage.

Voltage Unbalance In three-phase networks condition in which the rms values of the phase voltages or the phase angles between consecutive phases are not equal.

Wind Farm Control System The control system at the Wind Farm Power Station which provides for Active-Power Control, Frequency Response, ramp rate control and other WTG control features.

Wind Farm Power Station (WFPS) A Site containing at least one WTG.

Wind Farm Power Station Availability The amount of MW the wind farm can produce given favourable wind conditions

Wind Farm Power Station A measure of the maximum Active Power output which can be produced by a MW Availability Declaration Wind Farm Power Station given favourable wind conditions. Account shall be taken of partial and/or full outages of individual WTG within the Wind Farm Power Station.

Wind Farm Power Station Operator The operator of the Wind Farm Power Station

Wind Turbine Generator (WTG) A Generation Unit(s) generating electricity from wind

Annex 1

Supplementary Publications

- Item 1** European Standard EN 50160
- Item 2** Customer Charter- ESB Networks
- Item 3** Guide to the Process for connection to the Distribution System
- Item 4** National Code of Practice for Customer Interface
- Item 5** Conditions for Connection to the Distribution System
- Item 6** General Conditions for Connection of Industrial and Commercial Customers and Generators to the Distribution System

- Item 7** Conditions Governing Connection to the Distribution System: Connections at MV and 38kV; and Generators at LV, MV and 38kV
- Item 8** General Specification for MV Substation Buildings (Specification No. 13320)

- Item 9** Domestic Supply-Procedures and Conditions for Supply to New House from Overhead Networks
- Item 10** Domestic Supply-Specification of Requirements for Supply to Housing Schemes

- Item 11** Distribution System Security & Planning Standards
- Item 12** SI no.44 of 1993. Part VIII – Regulations 33 to 35
- Item 13** The ESB Safety Rules 1993 (Electrical) (Transmission, Distribution and Marketing)
- Item 14** National Rules for Electrical Installations—ETCI.
- Item 15** National Rules for Electrical Installations Code of Practice for the selection and installation of low voltage generators.

Annex 2

DISTRIBUTION CODE DEROGATION – APPLICATION FORM

| | | |
|--|--|---|
| DEROGATION APPLICATION SUBMITTED BY: | DATE OF SUBMITTING APPLICATION: | DEROGATION APPLICATION NUMBER: (to be assigned by Distribution Code Review Group Secretary) |
| Contact Details for Derogation Applicant | | |
| Name: | Telephone Number: | |
| e-mail address: | | |
| DISTRIBUTION CODE CLAUSE FOR WHICH DEROGATION IS SOUGHT: | | |
| PLANT/APPARATUS FOR WHICH DEROGATION IS SOUGHT: | | |
| EXTENT OF NON-COMPLIANCE: | | |
| REASON FOR NON-COMPLIANCE: | | |
| LENGTH OF TIME FOR WHICH DEROGATION IS SOUGHT: | | |
| PROPOSAL FOR REMEDYING NON-COMPLIANCE (MILESTONES FOR REMEDYING NON-COMPLIANCE, COSTS, RISK FACTORS THAT | | |
| DETAILS OF SUPPORTING DOCUMENTATION FOR APPLICATION (IF ANY) ATTACHED | | |
| Please return this form to Review Panel Secretary by e-mail: DistCodePanel@mail.esb.ie | | |

